

**PARTS LIST  
OPERATING AND  
SERVICE MANUAL**



**LEGEND**

“P” SERIES  
BLOWERS

6” - 8” GEAR DIAMETER

**Models**

- GAF \_ \_ P \_
- GAG \_ \_ P \_
- GAH \_ \_ P \_

SB-7-622  
Version 03  
November, 2005

**MAINTAIN BLOWER RELIABILITY AND PERFORMANCE  
WITH GENUINE GARDNER DENVER  
PARTS AND SUPPORT SERVICES**

Factory genuine parts, manufactured to design tolerances, are developed for optimum dependability --- specifically for your blower. Design and material innovations are born from years of experience with hundreds of different blower applications. When you specify factory genuine parts you are assured of receiving parts that incorporate the most current design advancements . . . manufactured in our state-of-the-art blower factory under exacting quality standards.

Your **AUTHORIZED DISTRIBUTOR** offers all the backup you require. A worldwide network of authorized distributors provides the finest product support in the blower industry.

Your **AUTHORIZED DISTRIBUTOR** can support your

blower investment with these services:

1. Trained parts technical representatives to assist you in selecting the correct replacement parts.
2. Complete inventory of new machines and new, genuine factory parts.
3. A full line of factory tested AEON™ PD blower lubricants specifically formulated for optimum performance in all blowers.
4. Authorized Distributor service technicians are factory-trained and skilled in blower maintenance and repair. They are ready to respond and assist you by providing fast, expert maintenance and repair services.

**INSTRUCTIONS FOR DETERMINING BLOWER CONFIGURATION**

1. Face the blower drive shaft.
2. In a **VERTICAL** configuration, air flow is horizontal.
3. In a **HORIZONTAL** configuration, air flow is vertical.
4. In a vertical configuration, a **BOTTOM HAND** exists when the drive shaft is below the horizontal center line of the blower. A **TOP HAND** exists when the drive shaft is above the horizontal center line of the blower.
5. In a horizontal configuration, a **RIGHT HAND** exists when the drive shaft is to the right of the vertical center line of the blower. A **LEFT HAND** exists when the drive shaft is to the left of the vertical center line of the blower.

**INSTRUCTIONS FOR ORDERING REPAIR PARTS**

For pricing and ordering information, contact your nearest **AUTHORIZED FACTORY DISTRIBUTOR**.

When ordering parts, specify Blower **MODEL** and **SERIAL NUMBER** (see nameplate on unit).

Rely upon the knowledge and experience of your **AUTHORIZED DISTRIBUTOR** and let them assist you in making the proper parts selection for your blower.

**For the location of your local authorized Gardner Denver blower distributor refer to the yellow pages of your phone directory, check the Web site at [www.gardnerdenver.com](http://www.gardnerdenver.com) or contact:**

**Gardner Denver  
1800 Gardner Expressway  
Quincy, IL 62305  
Phone: (217) 222-5400  
Fax: (217) 221-8780**

## FOREWORD

Sutorbilt® blowers are the result of advanced engineering and skilled manufacturing. To be assured of receiving maximum service from this machine the owner must exercise care in its operation and maintenance. This book is written to give the operator and maintenance department essential information for day-to-day operation, maintenance and adjustment. Careful adherence to these instructions will result in economical operation and minimum downtime.

### **DANGER**

**Danger is used to indicate the presence of a hazard which will cause severe personal injury, death, or substantial property damage if the warning is ignored.**

### **WARNING**

**Warning is used to indicate the presence of a hazard which can cause severe personal injury, death, or substantial property damage if the warning is ignored.**

### **CAUTION**

**Caution is used to indicate the presence of a hazard which will or can cause minor personal injury or property damage if the warning is ignored.**

### **NOTICE**

**Notice is used to notify people of installation, operation or maintenance information which is important but not hazard-related.**

## SAFETY PRECAUTIONS

Safety is everybody's business and is based on your use of good common sense. All situations or circumstances cannot always be predicted and covered by established rules. Therefore, use your past experience, watch out for safety hazards and be cautious. Some general safety precautions are given below:

### **DANGER**

Failure to observe these notices could result in injury to or death of personnel.

- **Keep fingers and clothing away** from blower inlet and discharge ports, revolving belts, sheaves, drive coupling, etc.
- **Do not use the air discharge** from this unit for breathing - not suitable for human consumption.
- **Do not loosen or remove** the oil filler plug, drain plugs, covers, or break any connections, etc., in the blower air or oil system until the unit is shut down and the air pressure has been relieved.
- **Electrical shock** can and may be fatal.
- **Blower unit must be grounded** in accordance with the National Electrical Code. A ground jumper equal to the size of the equipment ground conductor must be used to connect the blower motor base to the unit base.
- **Open main disconnect switch**, tag and lockout before working on the control.
- **Disconnect the blower** unit from its power source, tag and lockout before working on the unit - the machine may be automatically controlled and may start at any time.

### **WARNING**

Failure to observe these notices could result in damage to equipment.

- **Stop the unit** if any repairs or adjustments on or around the blower are required.
- **Disconnect the blower** unit from its power source, tag and lockout before working on the unit - the machine may be automatically controlled and may start at any time.
- **Do not exceed** the rated maximum speed shown on the nameplate.
- **Do not operate unit** if safety devices are not operating properly. Check periodically. Never bypass safety devices.

## TABLE OF CONTENTS

### Page

Maintain Blower Reliability and Performance with Genuine Gardner Denver Parts and Support Services .....	i
Instructions for Ordering Repair Parts .....	i
Instructions for Determining Blower Configuration .....	i
Foreword .....	ii
Safety Precautions .....	iii
Index .....	v
List of Illustrations .....	v
Sutorbilt Legend Series Sutorbilt Blowers Matrix/Menu .....	vi
Introduction, Your Key To Trouble Free Service .....	1
Section 1, Equipment Check .....	2
Section 2, Installation .....	3
Section 3, Lubrication .....	6
Section 4, Operation .....	8
Section 5, Special Tools Required .....	11
Section 6, Disassembly Instructions .....	15
Section 7, Assembly Instructions .....	18
Section 8, Parts List .....	25
Warranty .....	Last Page

## INDEX

<p>Air Filters and Filter-Silencers ..... 7</p> <p>ASSEMBLY INSTRUCTIONS, SECTION 7 ..... 18</p> <p>Blower Configuration, Determining ..... i</p> <p>Blower Startup Checklist ..... 9</p> <p>Checklist, Blower Startup ..... 9</p> <p>DISASSEMBLY INSTRUCTIONS, SECTION 6 .. 15</p> <p>Drive End Lubrication ..... 7</p> <p>Drive Installation ..... 4</p> <p>EQUIPMENT CHECK, SECTION 1 ..... 2</p> <p>Filter-Silencers and Air Filters ..... 7</p> <p>Foreword ..... ii</p> <p>Foundation ..... 3</p> <p>Gear End Lubrication ..... 6</p> <p>Impeller End Clearance, Setting, ..... 22</p> <p>INSTALLATION, SECTION 2 ..... 3</p> <p>Installation, Location ..... 3</p> <p>Installation, Drive ..... 4</p> <p>Installing Timing Gears ..... 22</p> <p>Limitations, Operation ..... 8</p> <p>Location, Installation ..... 3</p> <p>Lubricant, Recommended ..... 6</p> <p>LUBRICATION, SECTION 3 ..... 6</p> <p>Lubrication</p> <p style="padding-left: 20px;">Drive End ..... 7</p> <p style="padding-left: 20px;">Filling Procedure ..... 6</p>	<p>Gear End ..... 6</p> <p>Lubrication Service ..... 6</p> <p>Matrix/Menu ..... vi</p> <p>Mechanical Seals, Assembly ..... 19</p> <p>Mounting Configurations ..... 3</p> <p>Mounting Feet, Repositioning ..... 3</p> <p>OPERATION, SECTION 4 ..... 8</p> <p>Outline Drawing and Parts List</p> <p style="padding-left: 20px;">Model GAF ..... 25, 26</p> <p style="padding-left: 20px;">Model GAG ..... 27, 28</p> <p style="padding-left: 20px;">Model GAH ..... 29, 30</p> <p>PARTS LIST, SECTION 5 ..... 25</p> <p>Piping ..... 4</p> <p>Precautions, Safety ..... 10</p> <p>Protective Materials, Removing ..... 2</p> <p>Recommended Lubricant ..... 6</p> <p>Removing Protective Materials ..... 2</p> <p>Repair Parts, Ordering Instructions ..... i</p> <p>Safety Precautions ..... iii, 10</p> <p>Setting Impeller End Clearance ..... 22</p> <p>SPECIAL TOOLS REQUIRED, SECTION 5 ..... 11</p> <p>Startup Checklist, Blower ..... 9</p> <p>Storage ..... 2</p> <p>Timing Gears, Installing ..... 22</p> <p>Trouble Shooting ..... 10</p> <p>YOUR KEY TO TROUBLE FREE SERVICE, INTRODUCTION ..... 1</p>
---	--

## LIST OF ILLUSTRATIONS

Figure 1	Blower Mounting Configuration ..... 3	3
Figure 2	Belt Drive Overhung Load Calculations ..... 5	5
Figure 3	Lubrication ..... 6	6
Figure 4	Approximate Oil Capacities ..... 6	6
Figure 5	Lubrication Recommendation ..... 7	7
Figure 6	Temperature Chart ..... 7	7
Figure 7	Maximum Operating Limitations ..... 8	8
Figure 8	Puller Plate - SK2154 ..... 11	11
Figure 9	Puller Plate - SK2150 ..... 12	12
Figure 10	Mechanical Seal Installation Tool - SK2152 ..... 13	13
Figure 11	Bearing Press Tool - Mechanical Seal Units ..... 14	14
Figure 24	Torque (Ft-Lbs) ..... 24	24

## SUTORBILT LEGEND SERIES SUTORBILT BLOWERS MATRIX/MENU

NOTICE TO CUSTOMER - To find the construction options for your blower unit, FILL IN THE BALANCE OF LETTERS OR NUMBERS FROM YOUR UNIT NAMEPLATE

COLUMN NUMBER:

G	A				P	
1	2	3	4	5	6	7

FOLLOW THE LINE DOWN AND OVER FROM EACH SPACE THUS FILLED IN TO FIND THE APPROPRIATE CONSTRUCTION OPTION WITH WHICH YOUR MACHINE IS EQUIPPED.

COLUMN 1 - BASIC DESIGNATOR \_\_\_\_\_

COLUMN 2 - PRODUCT FAMILY \_\_\_\_\_

COLUMN 3 - GEAR DIAMETER \_\_\_\_\_

- F. 6"
- G. 7"
- H. 8"

COLUMN 4 - CASE LENGTH \_\_\_\_\_

- L - Low Pressure
- M - Medium Pressure
- H - High Pressure

COLUMN 5 - CONFIGURATION \_\_\_\_\_

- A. Vertical-Top Hand-Central Timed
- B. Vertical-Bottom Hand-Central Timed
- C. Horizontal-Left Hand-Central Timed
- D. Horizontal-Right Hand-Central Timed

COLUMN 6 - DESIGN VERSION \_\_\_\_\_

COLUMN 7 - ADDITIONAL DESCRIPTION \_\_\_\_\_

- A. Lip Seal
- B. Mechanical Seal

# **INTRODUCTION**

## **YOUR KEY TO TROUBLE FREE SERVICE**

---

Thank you for investing in Sutorbilt quality. The Sutorbilt reputation for rugged dependability has been earned by over 50 years of service in demanding, industrial operations where downtime cannot be tolerated and efficient blower performance is expected.

Your Sutorbilt blower is a precision engineered blower that has been carefully manufactured and thoroughly tested at the state-of-the-art Gardner Denver Blower Factory in Sedalia, Missouri.

As with other precision machinery, there are several relatively simple installation, operation and maintenance

procedures that you must observe to assure optimum blower performance. There is no guesswork in the manufacture of your highly advanced Sutorbilt blower and there must be none in preparing the blower to get the job done in the field.

The purpose of this manual is to help you properly install, operate and maintain your Sutorbilt blower. It is essential that you review all sections of this manual in preparation for installing your blower. Follow the instructions carefully and you will be rewarded with trouble-free Sutorbilt service . . . year in and year out.



## SECTION 1 EQUIPMENT CHECK

Before uncrating, check the packing slip carefully to be sure all the parts have been received. All accessories are listed as separate items on the packing slip, and small important accessories such as relief valves can be overlooked or lost. After every item on the packing slip has been checked off, uncrate carefully. Register a claim with the carrier for lost or damaged equipment.

### **WARNING**

**Customers are cautioned to provide adequate protection, warning and safety equipment necessary to protect personnel against hazards involved in installation and operation of this equipment in the system or facility.**

### STORAGE

Your Sutorbilt Blower was packaged at the factory with adequate protection to permit normal storage for up to six (6) months.

If the unit is to be stored under adverse conditions or for extended periods of time, the following additional measures should be taken to prevent damage.

1. Store the blower in a clean, dry, heated (if possible) area.
2. Make certain inlet and discharge air ports are tightly covered to prevent foreign material from entering the air box.
3. All exposed, non-painted surfaces should be protected against rust and corrosion.
4. Provide adequate protection to avoid accidental mechanical damage.
5. In high humidity or corrosive environments, additional measures may be required to prevent rusting of the blower internal surfaces.
6. To prevent rusting of gears, bearings, etc., the oil reservoirs may be filled with normal operating oil.

### **CAUTION**

**Before running the blower, drain the oil and replace to the proper operating level with clean, fresh lubricant.**

7. Rotate the blower shaft (10 to 25 turns) monthly during storage. Inspect the blower shaft (near the shaft seal area) monthly and spray with rust inhibitor if needed.
8. For long term storage (over six (6) months), contact Sutorbilt Customer Service for recommendations.

### REMOVING PROTECTIVE MATERIALS

The shaft extension is protected with rust inhibitor which can be removed with any standard solvent.

### **CAUTION**

**Follow the safety directions of the solvent manufacturer.**

Blower inlet and outlet are temporarily capped to keep out dirt and other contaminants during shipment. These covers must be removed before start-up.

The internal surfaces of all Sutorbilt units are mist sprayed with a rust preventative to protect the machine during shipment. Remove this film upon initial startup, using any commercial safety solvent. Care should be exercised to lock out the blower to prevent start-up.

### **WARNING**

**Rotating components will cause severe injury in case of personal contact. Keep hands away from blower inlet and discharge ports.**

# SECTION 2 INSTALLATION

## LOCATION

If possible, install the blower in a well lit, clean, dry place with plenty of room for inspection and maintenance.

## FOUNDATIONS

For permanent installations we recommend concrete foundations be provided, and the equipment should be grouted to the concrete. It is necessary that a suitable base be used, such as a steel combination base under blower and motor, or a separate sole plate under each. Before grouting, equipment must be leveled, free of all strains, and anchored so no movement will occur during setting of grout. After grout has completely hardened, a recheck is necessary to compensate for shrinkage, etc. If required, add shims under blower feet after final tightening of foundation anchor bolts to remove strain from the blower housing.

Where jack screws or wedges are used during grouting, they must be backed off or removed before final tightening of anchor bolts.

Where a concrete foundation is not feasible, care must be taken to insure that equipment is firmly anchored to adequate structural members.

## MOUNTING CONFIGURATIONS

The blower flex-mount design enables horizontal and vertical mounting configurations with top or bottom hand, right or left hand shaft positioning. The units are center timed allowing rotation in either direction (refer to FIGURE 1). If converting a blower from vertical to horizontal, or horizontal to vertical mounting configuration, additional mounting feet will be required.

## REPOSITIONING THE MOUNTING FEET:

1. Position the mounting feet to the desired location and snug the capscrew.
2. Place the blower on its feet on a flat surface.
3. Loosen mounting feet capscrews and level unit up. The bench or blower base flatness should be within .002 of an inch.

## NOTICE

**If the unit is not flat within .002 of an inch, it will be necessary to shim the blower feet at installation.**

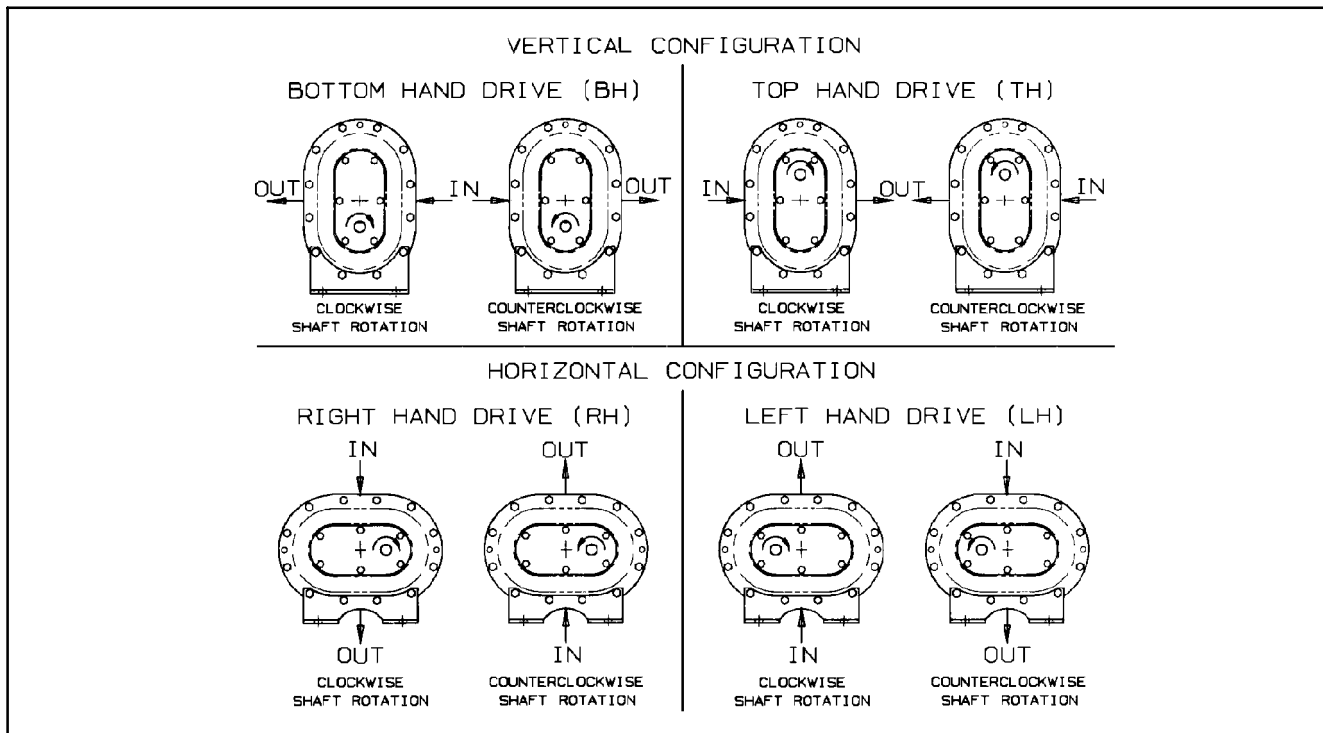

FIGURE 1 - BLOWER MOUNTING CONFIGURATIONS

4. Secure the mounting feet capscrews to the torque value in FIGURE 24, page 24.

## NOTICE

**When changing mounting configuration, it may be necessary to reposition vent plug (B), and drain plug (A). Refer to FIGURE 3, page 6, for correct location.**

### DRIVE INSTALLATION

When selecting a V-belt drive, check to be sure the shaft overhung load limitation is not exceeded. Refer to FIGURE 2, page 5, for overhung load calculations and limitations.

Belt drives must be carefully aligned. Motor and blower pulleys must be parallel to each other and in the same plane within 1/32 inch. Belt tension should be carefully adjusted to the belt manufacturer's recommendation using a belt tension gauge. Check tension frequently during the first day of operation.

## WARNING

**Overtightening belts leads to heavy bearing loads and premature failure.**

On the direct connected units, alignment and lubrication of couplings to specifications of the coupling manufacturer is very important. When mounted drives are supplied from the factory, proper alignment has been established before shipment. However, during shipping, handling and installation, it is likely that the alignment has been disturbed and final adjustment must be made before startup.

## WARNING

**Exceeding overhung load limitations leads to unwarrantable premature bearing failure and shaft breakage.**

The location of the sheave on the blower shaft greatly affects the stress in the shaft. The optimum blower

sheave positioning is as close as possible to the blower drive cover, not to exceed dimension "C" in Drive Shaft Illustration, FIGURE 2, page 5.

The calculated shaft moment must not exceed the maximum allowable moment listed in Maximum Allowable Moment Chart, FIGURE 2, page 5. If the calculated shaft moment exceeds the maximum allowable moment:

- Increase Sheave Diameters to Reduce Belt Pull
- Use Jackshaft Drive
- Use Direct Coupled or Gearbox Drive

To calculate shaft moment for a given V-Belt Drive Arrangement:

1. Use the formula for Calculation of Belt Pull, FIGURE 2, page 5, to calculate belt pull. Refer to Arc of Contact Factor Chart, FIGURE 2, page 5.
2. Insert the calculated belt pull into the formula for Calculation of Shaft Moment, FIGURE 2, page 5, to arrive at the calculated shaft moment.

### PIPING

Inlet and discharge connections on all blowers are large enough to handle maximum volume with minimum friction loss. Reducing the pipe diameter on either inlet or discharge will only create additional line loss and increase the overall pressure differential.

Excessive weight and thermal expansion of piping and fittings will cause internal misalignment and premature wear. Never allow the blower to carry the weight of the pipe. If possible, a spool or sleeve-type expansion joint should be installed between the unit and the piping. Where a flexible connection is not practical, the weight of the rigid connection must be separately supported.

All system piping must be cleaned internally before connecting to the blower.

## WARNING

**Sutorbilt blowers are shipped dry from the factory. Do not attempt to operate the blower before following proper lubrication instructions. Permanent damage to the gears, bearings and seals will occur.**

Gear Diameter (Inches)	Dimensions (Inches)			Maximum Allowable Moment (LB-IN)
	A	B	C (Max)	
6	4.08	1.14	.38	1788
7	4.50	1.31	.38	3000
8	5.57	1.77	.38	4144

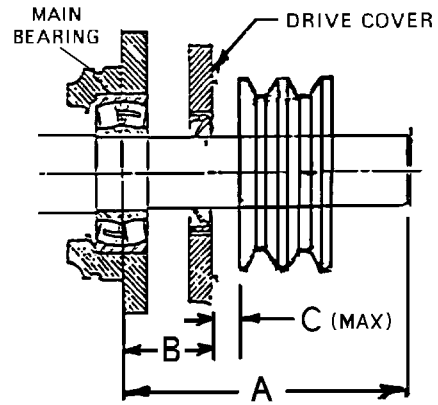

**MAXIMUM ALLOWABLE MOMENT**

**DRIVE SHAFT ILLUSTRATION**

Z	Ac	Z	Ac	Z	Ac	Z	Ac	Z	Ac	Z	Ac
0.000	1.000	0.250	0.966	0.500	0.926	0.750	0.879	1.000	0.823	1.250	0.751
0.025	0.997	0.275	0.962	0.525	0.922	0.775	0.874	1.025	0.816	1.275	0.742
0.050	0.994	0.300	0.958	0.550	0.917	0.800	0.869	1.050	0.810	1.300	0.734
0.075	0.990	0.325	0.954	0.575	0.913	0.825	0.864	1.075	0.803	1.325	0.725
0.100	0.987	0.350	0.951	0.600	0.908	0.850	0.858	1.100	0.796	1.350	0.716
0.125	0.983	0.375	0.947	0.625	0.904	0.875	0.852	1.125	0.789	1.375	0.706
0.150	0.980	0.400	0.943	0.650	0.899	0.900	0.847	1.150	0.782	1.400	0.697
0.175	0.977	0.425	0.939	0.675	0.894	0.925	0.841	1.175	0.774	1.425	0.687
0.200	0.973	0.450	0.935	0.700	0.889	0.950	0.835	1.200	0.767		
0.225	0.969	0.475	0.930	0.725	0.884	0.975	0.829	1.225	0.759		

**ARC OF CONTACT FACTORS**

$$\text{Belt Pull} = \left[ \frac{2.5 - A_c}{A_c} \right] \left[ \frac{125954 \times H_p \times S.F.}{D \times \text{RPM}} \right]$$

- Key:
- A<sub>c</sub> = Arc of Contact Factor (Refer to Arc of Contact Factors Chart above)
  - H<sub>p</sub> = Blower Horsepower for Operating Conditions
  - S.F. = Actual Drive Service Factor
  - D = Blower Sheave Pitch Diameter in Inches
  - RPM = Blower Sheave Speed
  - Z =  $\left[ \frac{\text{Large Sheave Pitch Diameter (in)} - \text{Small Sheave Pitch Diameter (in)}}{\text{Sheave Center Distance (in)}} \right]$

**CALCULATION OF BELT PULL**

$$\text{Shaft Moment (LB-IN)} = \text{Belt Pull} \times \left[ B + C + \left( \frac{\text{Sheave Width}}{2} \right) \right]$$

**CALCULATION OF SHAFT MOMENT**

**FIGURE 2 - BELT DRIVE OVERHUNG LOAD CALCULATIONS**

## SECTION 3 LUBRICATION

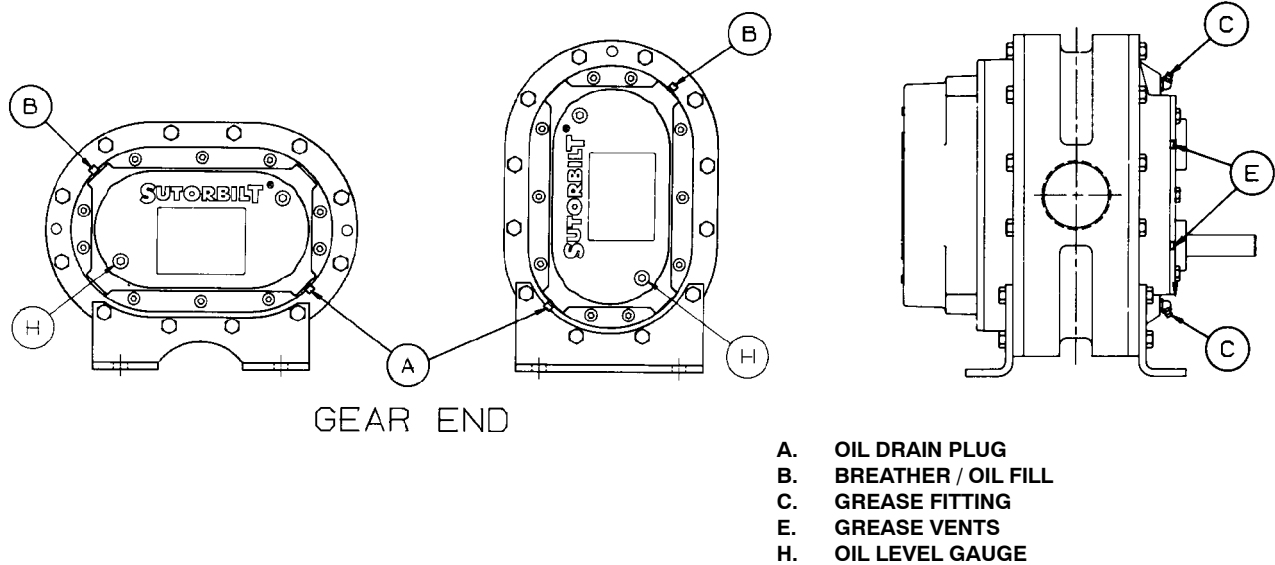

FIGURE 3 - LUBRICATION

At the gear end the timing gear teeth are lubricated by being partially submerged in oil. The gear teeth serve as oil slingers for gear end bearings. At the drive end the bearings are grease lubricated.

bearings through grease fittings located at (C). When regreasing, the old grease will be forced out of the vents (E). To prevent damage to seals, these vents must be open at all times.

### FILLING PROCEDURE

Refer to FIGURE 3. Remove the breather (B) from the gear cover. Add oil to the gear case until it reaches the center line of the oil level gauge (H). Secure breather (B) in its correct location.

### RECOMMENDED LUBRICANT

### LUBRICATION SERVICE

Add fresh oil as required to maintain proper level. The oil should be drained, flushed and replaced every 1500 hours or more frequently if inspection so indicates. The oil drain plug is located at (A).

Gear Diameter	Vertical	Horizontal
6"	1-1/4 PT.	3 PT.
7"	1-2/3 PT.	3-1/2 PT.
8"	2-1/2 PT.	7 PT.
Quantities are for purchase estimates only.		

FIGURE 4 - APPROXIMATE OIL CAPACITIES

### WARNING

**Do not overfill as this will tend to cause excessive heating of the gears and may damage the unit.**

### GEAR END LUBRICATION

AEON PD is formulated especially for positive displacement blower service to provide maximum blower protection at any temperature. One filling of AEON PD will last a minimum of 4 times longer than a premium mineral oil. Refer to FIGURE 5, page 7.

Bearings on the drive end of the blower require grease lubrication every 500 hours of operation. Lubricate the

AEON PD 1 Quart Bottle Part No. 28G23  
 AEON PD 12 Quart Case Part No. 28G24

Blower Discharge Temperature		Factory Tested Recommended and Approved Lubricant
° F	° C	
32°	0°	AEON PD Synthetic Blower Lubricant One Superior Lubricant For All Operating Temperatures
100°	38°	
275°	135°	
350°	177°	

FIGURE 5 - TEMPERATURE CHART

### DRIVE END LUBRICATION

Grease drive end bearings every 500 hours of operation with a non-corrosive, extreme pressure bearing grease of the following specification:

Blower Discharge Temperature	Grease Specification
Up to 350° F (177° C)	NLGI Grade 2 EP

If not using AEON PD synthetic blower lubricant, use oils with rust and oxidation inhibitors, anti-foam additives and the viscosities listed in FIGURE 6.

### AIR FILTERS AND FILTER SILENCERS

Blower Discharge Temperature	Oil Grade ISO	Oil Viscosity SUS @ 100° F
32° F to 100° F (0° C to 38° C)	100	465
100° F to 225° F (38° C to 105° C)	150	700
225° F to 300° F (105° C to 149° C)	220	1000
Over 300° F (149° C)	*	*

\* The oil viscosity must be 70 SUS minimum at discharge temperature minus 50° F.

FIGURE 6 - LUBRICATION RECOMMENDATION

 <b>WARNING</b>
<b>Servicing the air filters is one of the most important maintenance operations to be performed to insure long blower life.</b>

Servicing frequency of filter elements is not time predictable. A differential pressure indicator, with a continuous gauge reading, should be installed across the inlet filter. It will tell how much of the service life of the filter element has been used. It will also eliminate both premature filter servicing and premature blower failure due to a plugged filter when the filter pressure drop is used to establish maintenance points.

In all cases refer to the filter manufacturer's service instructions. Due to the many types of filters, it is not practical to give specific instructions covering all models.

<b>NOTICE</b>
<b>No matter what type of filter is used, always make sure all seats, gaskets, clamps and hose connections on the filter and inlet line are absolutely air tight. Each time the filter is serviced, inspect interior of the blower for dirt.</b>

## SECTION 4 OPERATION

Future operating problems can be avoided if proper precautions are observed when the equipment is first put into service.

Before starting under power, the blower should be turned over by hand to make certain there is no binding, or internal contact.

Each size blower has limits on pressure differential, running speed, and discharge temperature which must not be exceeded. These limits are shown in the following tabulation.

### **WARNING**

**Operating beyond the specified operating limitations will result in damage to the unit.**

It is important that the pressures and temperatures are measured directly at the ports of the blower to avoid error that may be caused by intervening pipe runs, fittings, etc.

Relief valves should be used to protect against excessive pressure or vacuum conditions. These valves

should be tested at initial startup to be sure they are adjusted to relieve at or below the maximum pressure differential rating of the blower.

### **NOTICE**

**Relief valves should be placed as close as possible to the blower inlet or discharge.**

In some instances, pressure may be relieved at a lower point than the blower maximum in order to protect the motor or the equipment served by the blower.

Discharge temperature switches are recommended to protect against excessive inlet restriction or inlet temperatures. Check valves in the discharge line on pressure blowers and in the inlet line on vacuum blowers are recommended to protect the blower from motoring backwards when shut down under load.

### **LIMITATIONS**

For information regarding limitations, refer to FIGURE 7, below.

<b>MAXIMUM OPERATING LIMITATIONS</b>					
SIZE	RPM	PRESSURE PSI	VACUUM IN HG	DISCHARGE TEMPERATURE °F	
6LP	2350	7	14	260	
6MP	2350	14	16	325	
6HP	2350	15	16	340	
7LP	2050	6	12	260	
7MP	2050	10	16	325	
7HP	2050	15	16	340	
8LP	1800	6	12	260	
8MP	1800	10	16	325	
8HP	1800	15	16	340	

**DO NOT EXCEED THESE LIMITS**

### **NOTICE**

**Blower speed, line losses, elevation, and increased inlet temperatures will affect the maximum operating limitations.**

FIGURE 7 - MAXIMUM OPERATING LIMITATIONS

## BLOWER STARTUP CHECKLIST

This startup procedure should be followed during the initial installation and after any shutdown periods or after the blower has been worked on or moved to a new location. It is suggested that the steps be followed in sequence and checked off ( ✓ ) in the boxes provided.

1. Check the unit and all piping for foreign material and clean if required.
2. Check the flatness of the feet and the alignment of the drive. Feet that are bolted down in a bind can cause case distortion and internal rubbing. Misaligned V-drives can cause the impellers to rub against the headplates and cause a reduction in the volumetric efficiency of the unit. Misaligned couplings can ruin bearings.
3. If blower is V-belt driven, check the belt tension and alignment. Over-tensioned belts create heavy bearing loads which leads to premature failure.
4. Be sure adequate drive guards are in place to protect the operator from severe personal injury from incidental contact.
5. Check the unit for proper lubrication. Proper oil level cannot be overemphasized. Too little oil will ruin bearings and gears. Too much oil will cause overheating and can ruin gears and cause other damage. Insure drive end bearings are greased.
6. With motor locked out, turn the drive shaft by hand to be certain the impellers do not bind.
7. "Jog" the unit with the motor a few times to check rotation and to be certain it turns freely and smoothly.
8. The internal surfaces of all Sutorbilt units are mist sprayed with a rust preventive to protect the machine during the shipping and installation period. This film should be removed upon initial start-up.
9. Start the unit and operate 15 minutes at no load. During this time, check for hot spots and other indications of interference.
10. Apply the load and observe the operation of the unit for one hour. Check frequently during the first day of operation.
11. If malfunctions occur, do not continue to operate. Problems such as knocking impellers can cause serious damage if the unit is operated without correction.



## SAFETY PRECAUTIONS

1. Do not operate blower with open inlet or outlet port.
2. Do not exceed specified vacuum or pressure limitations.
3. Do not operate above or below recommended blower speed range.
4. Blower is not to be used where non-sparking equipment is specified.
5. Do not operate without belt guard or coupling shield.

 <b>WARNING</b>
<b>Do not exceed sheave or coupling manufacturers' rim speed limit.</b>

6. The blower and blower discharge piping may be extremely hot and can cause skin burns on contact.
7. Prolonged exposure may require ear protection.

## TROUBLE SHOOTING

No matter how well the equipment is designed and manufactured, there may be times when servicing will be required due to normal wear, the need for adjustment, or various external causes. Whenever equip-

ment needs attention, the operator or repairman should be able to locate the cause and correct the trouble quickly. The Trouble Shooting Chart below is provided to assist the mechanic in those respects.

PROBLEM	POSSIBLE CAUSES	SOLUTION
Knocking	<ol style="list-style-type: none"> <li>1. Unit out of time.</li> <li>2. Distortion due to improper mounting or pipe strains.</li> <li>3. Excessive pressure differential.</li> <li>4. Worn gears.</li> <li>5. Worn bearings.</li> </ol>	<ol style="list-style-type: none"> <li>1. Retime impellers.</li> <li>2. Check mounting alignment and relieve pipe strains.</li> <li>3. Reduce to manufacturer's recommended pressure. Examine relief valve, re-set if necessary.</li> <li>4. Replace timing gears.</li> <li>5. Replace bearings.</li> </ol>
Excessive blower temperature.	<ol style="list-style-type: none"> <li>1. Too much oil in gear case.</li> <li>2. Too low operating speed.</li> <li>3. Clogged filter or muffler.</li> <li>4. Excessive pressure differential.</li> <li>5. Worn impeller clearances.</li> <li>6. Internal contact.</li> </ol>	<ol style="list-style-type: none"> <li>1. Reduce oil level.</li> <li>2. Increase blower speed.</li> <li>3. Remove cause of obstruction.</li> <li>4. Reduce pressure differential across the blower.</li> <li>5. Replace impeller.</li> <li>6. Correct clearances.</li> </ol>
Impeller end or tip drag.	<ol style="list-style-type: none"> <li>1. Insufficient assembled clearances.</li> <li>2. Case or frame distortion.</li> <li>3. Excessive operating pressure.</li> <li>4. Excessive operating temperature.</li> </ol>	<ol style="list-style-type: none"> <li>1. Correct clearances.</li> <li>2. Check mounting and pipe strain.</li> <li>3. Remove cause.</li> <li>4. Remove cause.</li> </ol>
Lack of volume.	<ol style="list-style-type: none"> <li>1. Slipping belts.</li> <li>2. Worn clearances.</li> </ol>	<ol style="list-style-type: none"> <li>1. Tighten belts.</li> <li>2. Re-establish proper clearances.</li> </ol>
Excessive bearing or gear wear.	<ol style="list-style-type: none"> <li>1. Improper lubrication.</li> </ol>	<ol style="list-style-type: none"> <li>1. Correct lubrication level. Replace dirty oil.</li> </ol>
Loss of oil.	<ol style="list-style-type: none"> <li>1. Headplate, gear case or drive cover vents plugged.</li> <li>2. Worn seal.</li> </ol>	<ol style="list-style-type: none"> <li>1. Clean vents.</li> <li>2. Replace seals.</li> </ol>

**SECTION 5  
SPECIAL TOOLS REQUIRED**

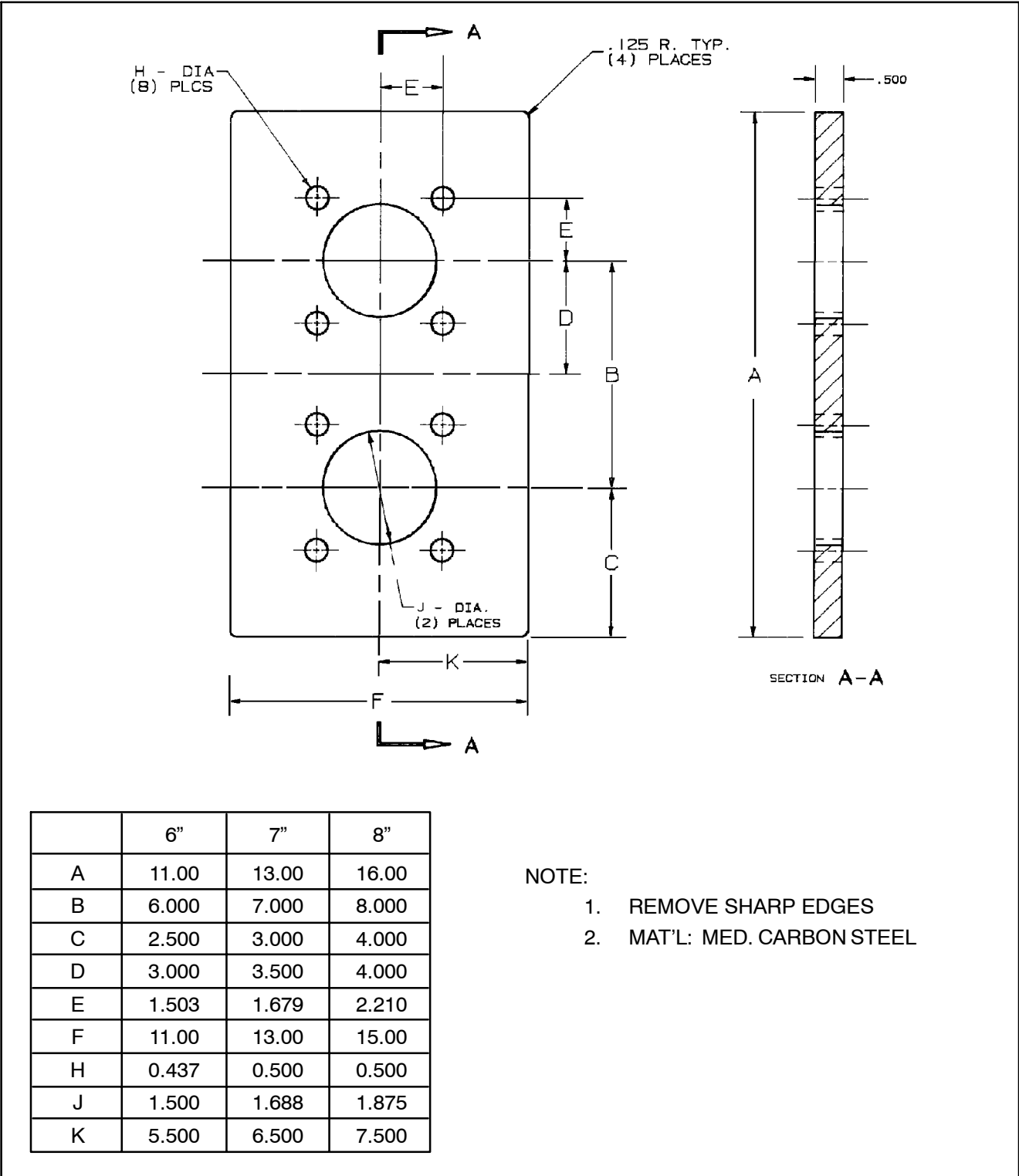
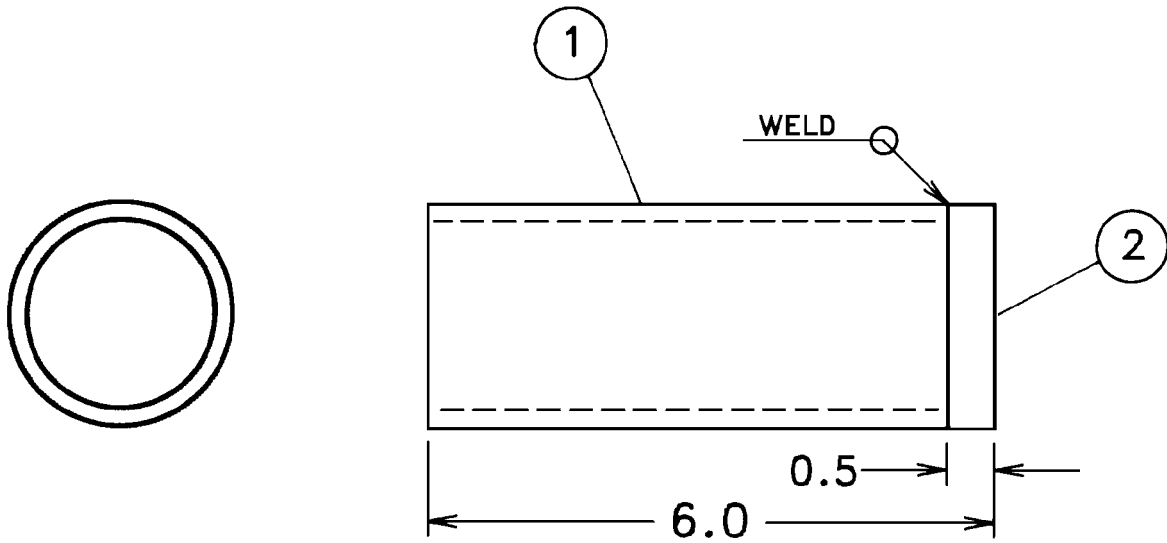
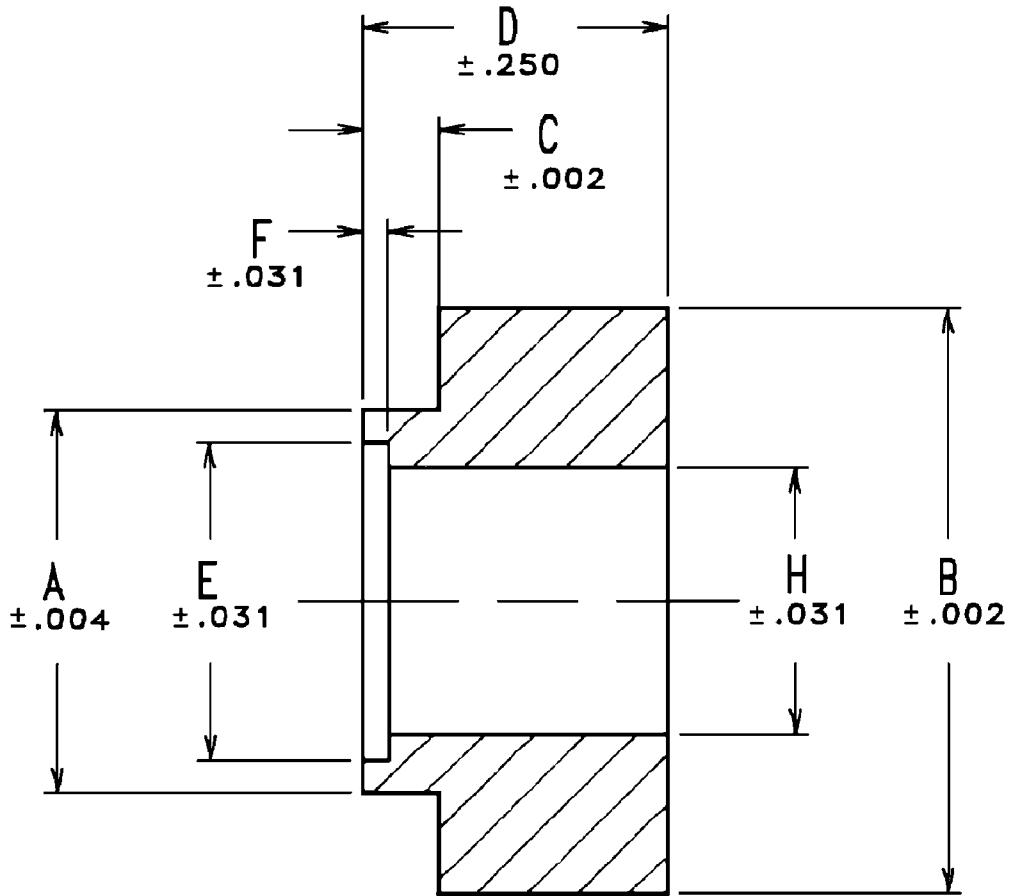

FIGURE 8 - PULLER PLATE - SK2154



1	PIPE - STEEL 2" SCH 80
2	MED. CARBON STEEL 1/2"

FIGURE 9 - GEAR DRIVER - SK2150



NOTES:

1. BREAK SHARP EDGES
2. MATERIAL: 4140
3. HEAT TREAT TO RC 48 - 52

UNIT SIZE	A	B	C	D	E	F	H
6"	2.748	3.150	0.515	1.890	2.450	0.125	1.400
7"	3.000	3.543	0.424	1.863	2.423	0.150	1.616
8"	3.250	3.938	0.407	2.000	2.800	0.150	1.813

FIGURE 10 - MECHANICAL SEAL INSTALLATION TOOL - SK2152

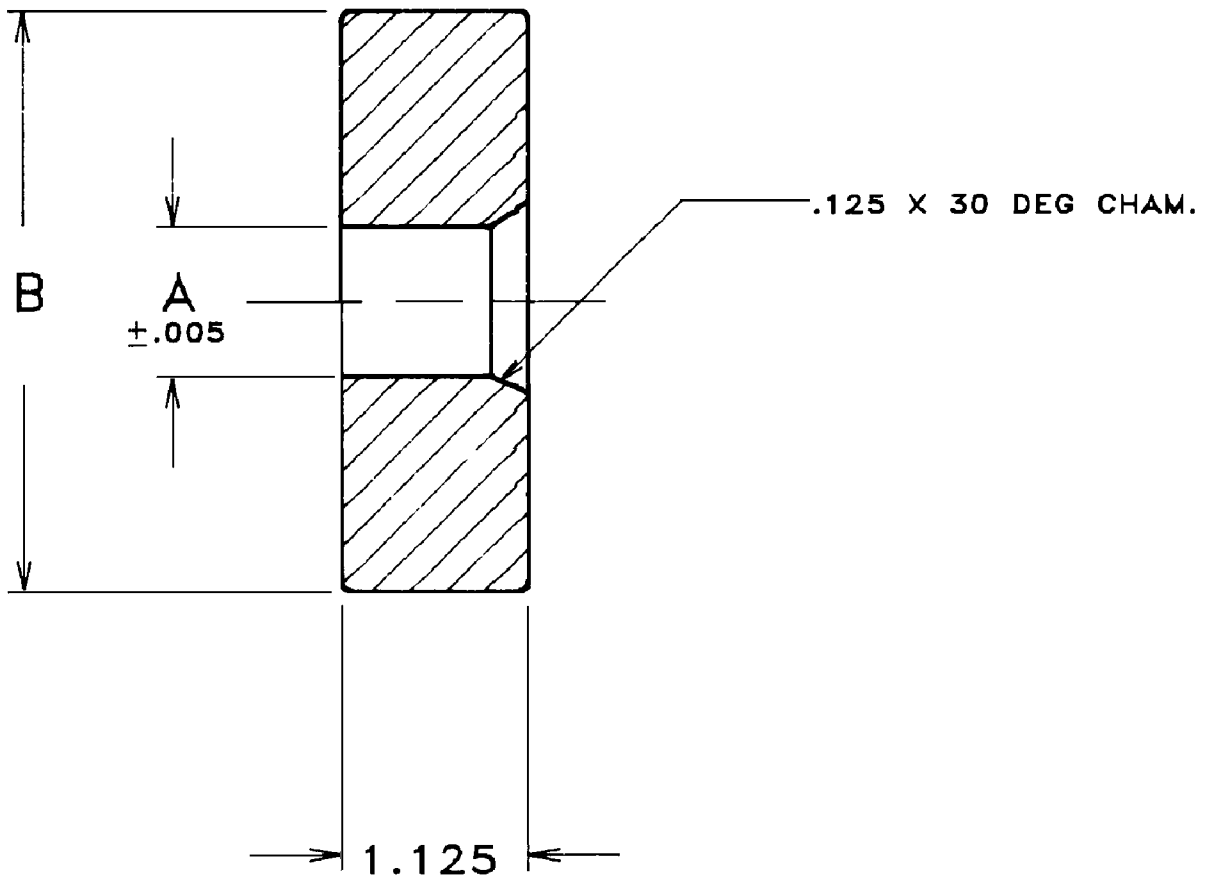

NOTES:

1. BREAK SHARP EDGES
2. MATERIAL: 4140
3. HEAT TREAT TO RC 52 - 56

UNIT SIZE	A	B
6"	1.900	5.000
7"	2.087	5.500
8"	2.406	6.000

FIGURE 11 - BEARING PRESS TOOL - MECHANICAL SEAL UNITS - SK2156

## SECTION 6 DISASSEMBLY INSTRUCTIONS

### NOTICE

Numbers in parentheses ( ) refer to key numbers in assembly drawings on pages 25, 27 and 29.

1. Drain oil from gear case by removing drain plug (4).
2. Remove the socket head bolts (5) from the gear cover (3).
3. Remove the gear cover from gear headplate (18).

### NOTICE

The cover and gear headplate gasket tends to bond tightly to both surfaces. After socket head bolt removal, it is sometimes necessary to take a ball peen hammer and a blunt chisel and drive off the cover.

IMPORTANT:  
MARK ALL PARTS WITH A CENTER PUNCH SO

THEY CAN BE REASSEMBLED IN THE SAME POSITION (IMPELLERS, HEADPLATES, AND GEARS).

4. If the timing gears appear undamaged, the gear backlash must be checked to see if the gears can be salvaged.
  - A. Mount a magnetic base dial indicator on the gear headplate (see FIGURE 12).
  - B. Lock one impeller stationary by wedging a feeler gage between the impeller and the headplate.
  - C. The tip of the indicator should be placed at the center of the contact surface on a tooth of the gear on the free shaft.
  - D. Rock the impeller back and forth by hand and read the total rotational movement to the nearest .0005 inches. Do this at four gear mesh positions 90 degrees apart.
  - E. Permissible gear backlash is shown below.

GEAR DIA.	GEAR BACKLASH
6"	.002 - .003
7"	.003 - .005
8"	.003 - .006

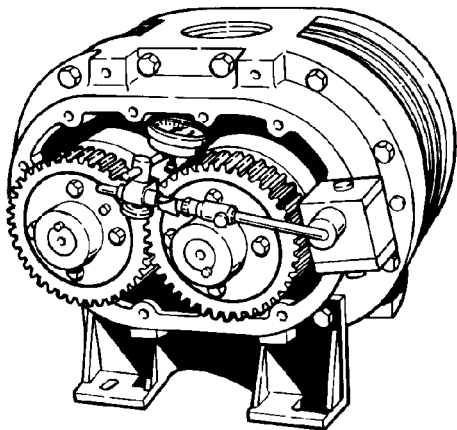

FIGURE 12

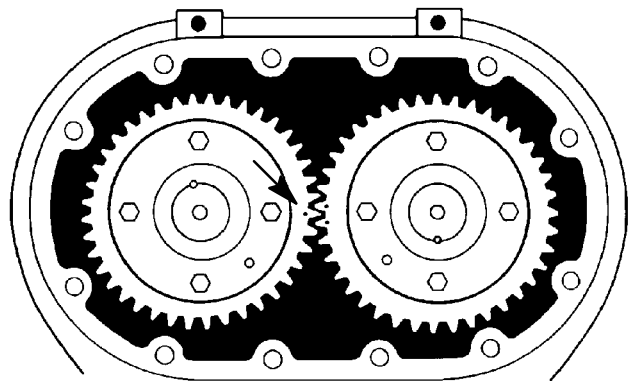

FIGURE 13

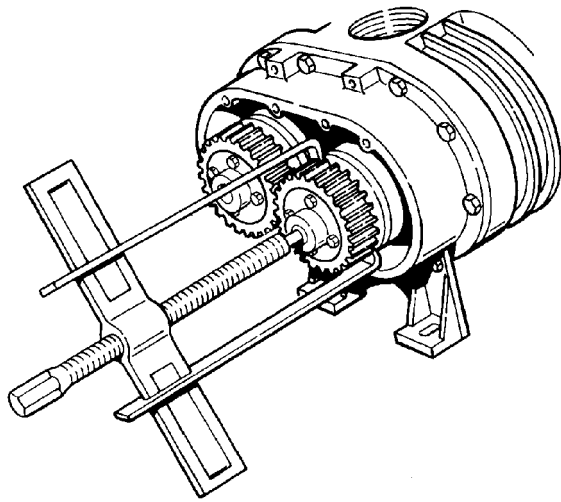

FIGURE 14

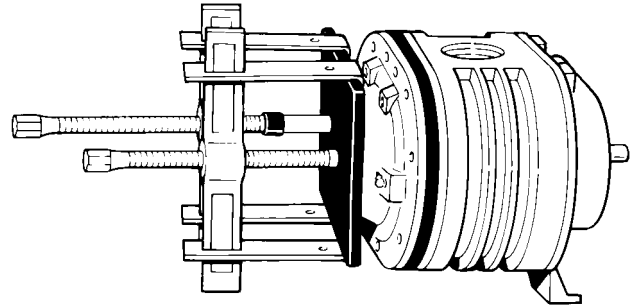

FIGURE 15

### NOTICE

**If backlash is above the specified limit, the gears are not necessarily unusable. Excessive play could be caused by worn bearings.**

5. If timing gears appear to be reusable, matchmark timing gear toothmesh by making small punch marks on the ends of meshing gear teeth with a pin punch and hammer (see FIGURE 13, page 15). The impeller tip to valley (throat) and the case to headplates should also be match marked to facilitate blower reassembly.
6. Remove each timing hub (39) and the timing gear (9) as a complete assembly with a gear puller. (See FIGURE 14). Do not remove timing bolts (38) or threaded taper pins (36), unless the gears or hubs will be replaced.

### NOTICE

**If replacing the timing gears (9), remove the timing hub taper pins (36) by placing washers or an oversized nut over the extending threaded area of the pin. Tighten a proper-sized nut on the pin and it will eject.**

7. Remove the four socket head cap screws (30) from the drive end bearing cover (29) and remove

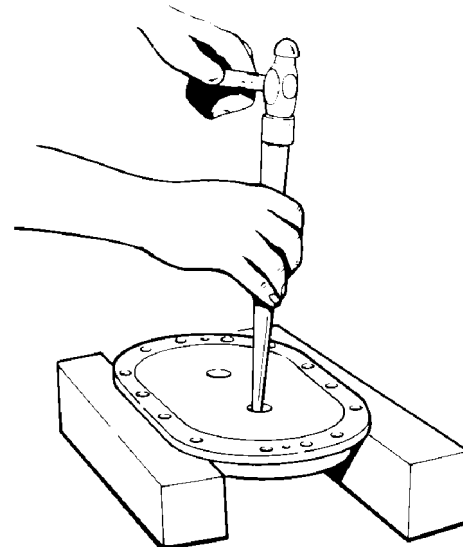

FIGURE 16

the cover. Drive shaft oil seal (31) should come free when cover is removed.

8. Remove mounting foot (17) from the drive headplate (24) by removing the capscrews (16).
9. Remove the capscrews (21) which secure the drive headplate (24) to the impeller case (22).
10. Using the fabricated puller plate shown on page 11, bolt to the drive headplate using the tapped holes used to secure the drive cover.
11. Install a gear puller to each shaft and attach the puller arms to the fabricated plate. Turn each puller only half a revolution at a time keeping the advance of the shafts as uniform as possible (see

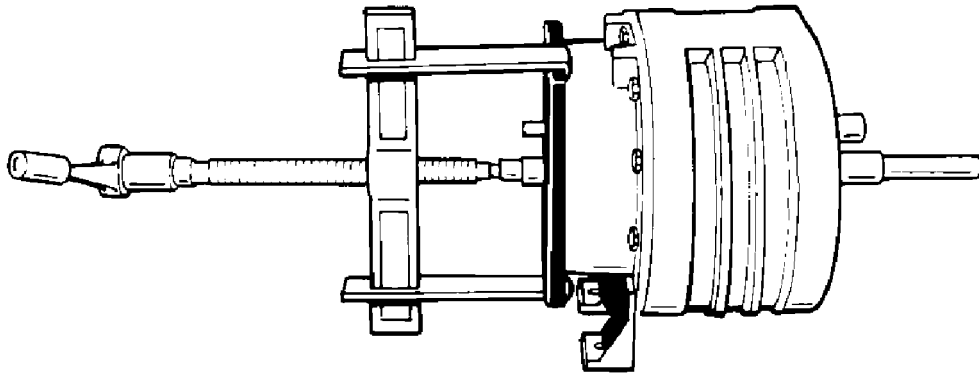

FIGURE 17

FIGURE 15, page 16). After the headplate has been removed, detach the puller plate.

12. Remove the two drive end bearings (14) from the drive headplate (24) using a ball peen hammer and punch (see FIGURE 16, page 16).



### CAUTION

**Exercise care not to damage the headplate bearing bores when removing bearings.**

13. Remove the drive end spacers (33), (34) and (41). The grease seals (15) can now be driven out of the drive headplate with hammer and punch (see FIGURE 16, page 16). Discard the seals as they will not be reused. Replace grease seals each time the headplate is removed.

### NOTICE

**Seals and bearings should be replaced during overhaul as a matter of service policy.**

14. Remove the four cap screws (10) which fasten each bearing retainer (12) to the gear headplate.
15. Attach fabricated puller plate to the gear headplate using the tapped holes used to secure the bearing retainers.
16. Install a gear puller to one of the shafts and attach the puller arms to the fabricated plate (see FIGURE 17).
17. Push the impeller shaft through the gear headplate and remove the impeller assembly (23) (see FIGURE 17). Remove the other impeller assembly following the same procedure.
18. Remove mounting foot (17) from the gear headplate by removing 4 capscrews (16).
19. Remove the cap screws (21) securing the gear headplate to the impeller case. Located near each dowel pin on the headplate is a threaded hole. Insert a 3/8-16 UNC capscrew into each of the threaded holes. Tighten the screws evenly until the headplate separates from the impeller case.
20. Remove the two gear end bearings (14) from the gear headplate (18) as done in step 12.
21. Remove the bearing seal spacers (33) and oil seals (15) from the gear headplate as done in Step 13.



## SECTION 7 ASSEMBLY INSTRUCTIONS

### NOTICE

Numbers in parentheses ( ) refer to key numbers in assembly drawings on pages 25, 27 and 29.

1. Make sure all metallic parts are clean and free of any nicks or burrs.
2. Lubricate the outside diameter of the lip seal (15) with a light oil or grease. Install seals in both the drive head-plate (24) and gear headplate (18). The seal lip should always face towards the bearing or lubricant. New seals should be installed each time the headplate is removed.

### NOTICE

Make sure seals are fully seated. Use extreme care when installing.

### INSTALLING MECHANICAL SEALS

- A. Lightly coat the headplate bores with assembly lubricant.
- B. Refer to FIGURE 18. Install mechanical seal (A) into the headplate bore using a press and the correct driver shown on page 13. Drive the seal securely on to its seat.



### CAUTION

Use extreme care when installing seals in the headplate bores. Do not attempt to install the mechanical seals without the use of a press. Blows from a hammer or mallet can damage the fragile seal surface. Too much force can crush the seal casing. Make certain the seal is properly seated and undamaged before proceeding.

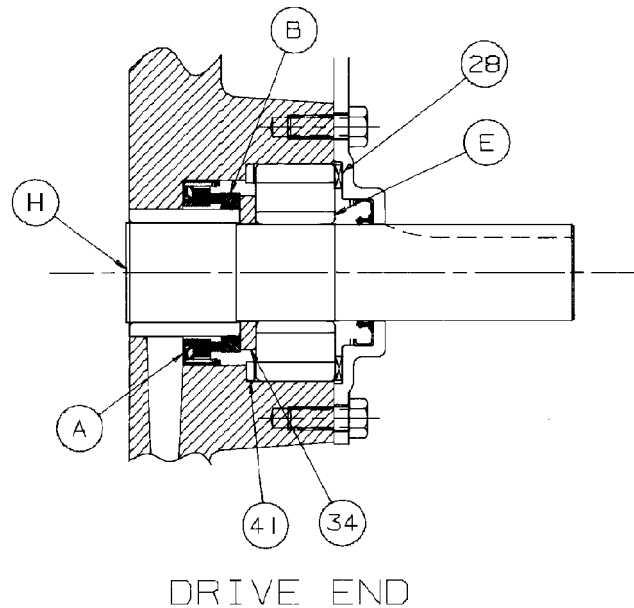
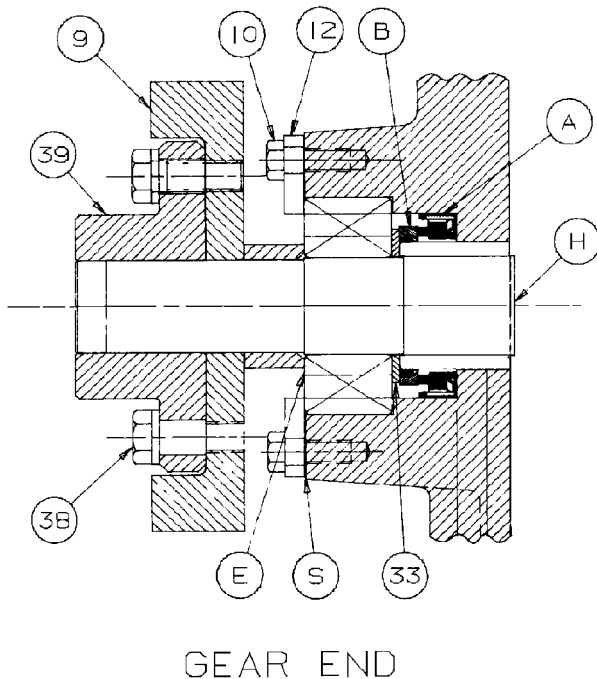

FIGURE 18

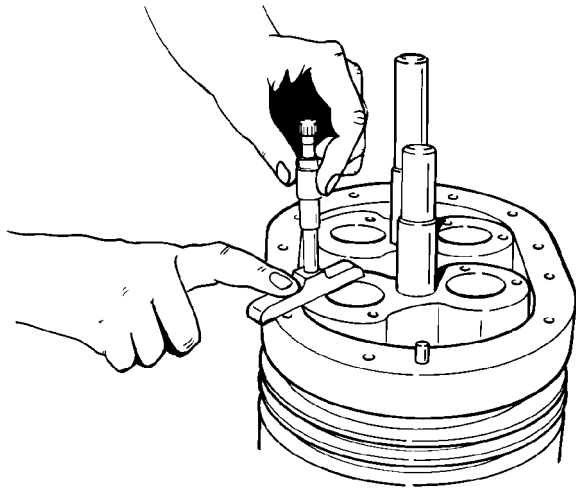

FIGURE 19

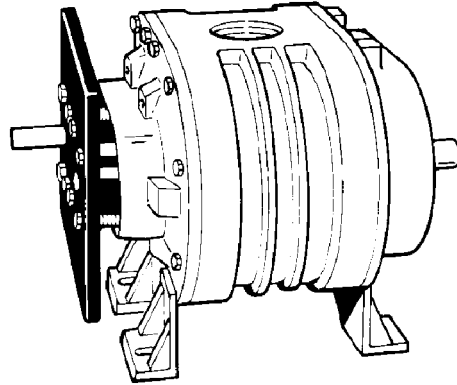



FIGURE 20

3. Assemble gear headplate (18) and mounting foot (17) to the impeller case with cap screws (21) and where the mounting foot is secured to the headplate use cap screws (16). The two positioning dowel pins (19) will ensure proper alignment of the headplate and impeller case. Also secure lifting lugs using cap screws (21) (see exploded assembly drawing page 25). Torque cap screws alternately and evenly. Refer to FIGURE 24, page 24, for torque specifications.
4. Apply a light oil or grease on the shaft seal areas and the bearing areas. Insert impellers into the gear headplate using the same headplate bores as used in the original assembly.

 <b>CAUTION</b>
<p><b>Seals are delicate; use extreme care when installing impeller shafts in the headplate bores. A piece of light shim stock wrapped around the shaft keyway will prevent cutting the seal lip.</b></p>

5. Position blower so that impellers are vertical, with the drive end on top. It will be necessary to use blocks in order for the unit to set level. Measure the total end clearance using a depth micrometer (see FIGURE 19).

If total clearance is not within the limits specified in FIGURE 21, page 20, it may be necessary to shim the case to obtain the proper total end clearance. The shim should be placed between the drive headplate and impeller case.

<p><b>NOTICE</b></p>
<p><b>If more than .007" shim is required, put .007" on the drive end and the remaining on the gear end.</b></p>

6. Assemble drive headplate (24) to impeller case as done in step 3 with the gear headplate. If shims were required, place shims between drive headplate and impeller case.
7. Insert bearing-seal spacers (34), (41) into the drive shaft headplate bore and spacer (33) into the remaining bores (see exploded view, page 25).

**MECHANICAL SEALS ONLY**

- A. Refer to FIGURE 18, page 18. Lightly coat the impeller shaft (H) and the inside diameter of the mating ring (B) with assembly lubricant.
- B. Install the mating ring (B) on the shaft only far enough to install spacer (34), (41) in the bore and allow for the bearing inner race (E) to be started on the shaft.

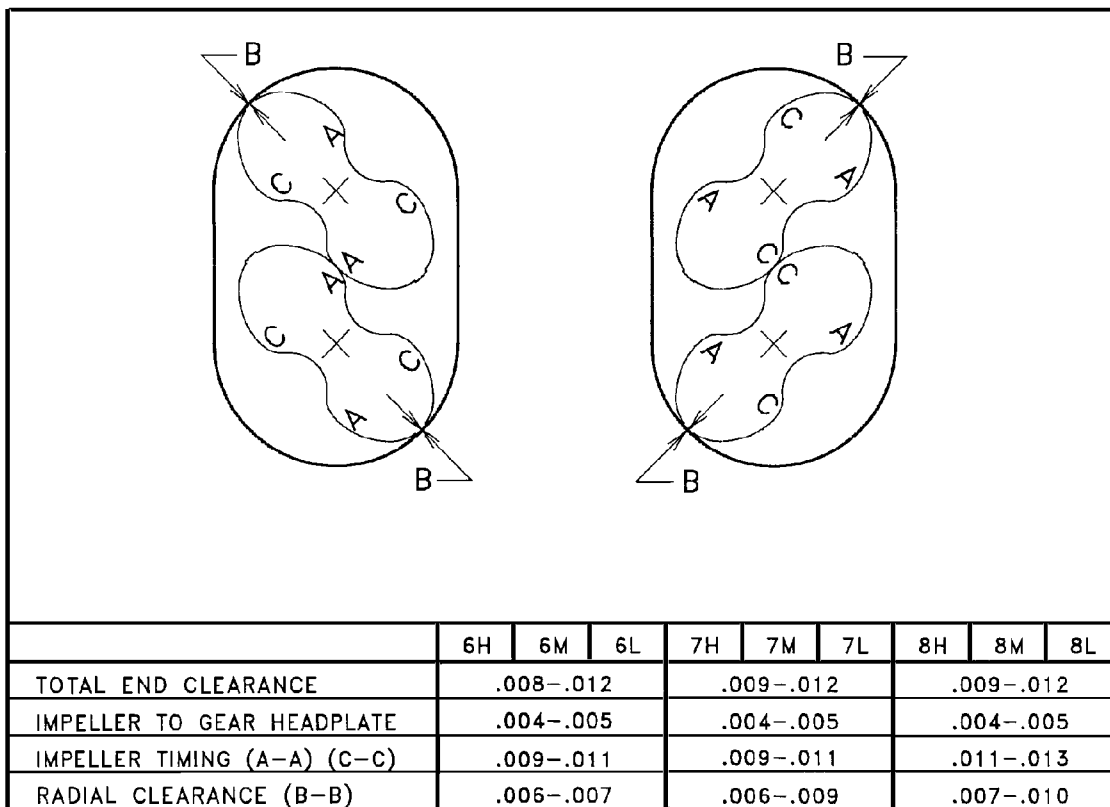

FIGURE 21



**CAUTION**

**Do not drive the mating ring down to the mechanical seal, as this can damage the seal.**

- C. Install mating ring (B) on the drive end short shaft and the gear end shafts as done in the previous step, but use spacer (33) (refer to gear end, FIGURE 18, page 18).
  - D. Brush the bearing inner race (E) with a light oil or grease.
  - E. Using a press and the bearing installation tool shown on page 14, install the spherical roller bearing (35) on the drive end drive shaft. Install the three double row ball bearings on the remaining shaft ends. Bearings will position the mating ring (B) to the proper depth with respect to the mechanical seal (A) when the installation tool is tight against the headplate.
8. Apply a light oil to the drive headplate bearing

bore, bearing inside diameter, and shaft seat. Install the spherical roller bearing (35) on the drive end drive shaft and the double row ball bearing (14) on the drive end driven shaft. Start the bearing in the bores without force.

9. Attach the puller plate shown on page 11 to the drive headplate using the tapped holes used to secure the drive cover (see FIGURE 20, page 19). Tighten the bolts so that the advance of the bearings stay as uniform as possible. Bearings should be pressed until fully seated in the bore.

**NOTICE**

**Bearings will not be flush with gear headplate bores when completely seated.**

10. Lubricate the gear end bearing fits with a light oil as described previously. Install gear end bearings (14) as far as possible without force. Use the fabricated plate, used to install the drive end bearings, to press the bearings on the shafts as described

in Step 9. Press bearings into the gear headplate until completely seated in the bearing bore.

## NOTICE

**Bearings will not be flush with gear headplate bores when completely seated.**

11. Impeller should now be checked for free axial movement by hitting the ends of the impeller shafts with the palm of your hand.
12. Push the impellers against the gear headplate and recheck the total end clearance between the drive headplate and the impellers (see FIGURE 21, page 20).
  - A. If total end clearance is insufficient, loosen impeller case to headplate bolts on either headplate, and move the headplate away from the case far enough to insert a paper shim in the amount equal to the insufficient clearance. Retighten case bolts and again check the total end clearance. Refer to FIGURE 21, page 20, for correct clearance.
  - B. Excessive end clearances normally will require new impeller assemblies, but in some circumstances the impeller case can be removed and reduced in width by machining off the amount of excess clearance.



## CAUTION

**These impeller-to-impeller and impeller-to-case clearances are extremely critical. Even though the blower may turn freely by hand when cold, under operating conditions, the parts expand, and the rotors are subject to slight deflection.**

**If the clearances are not sufficient, the impellers may contact each other or the housing with destructive results. If the clearances are too great, the blower may not develop the pressure or airflow that is required to perform its function.**

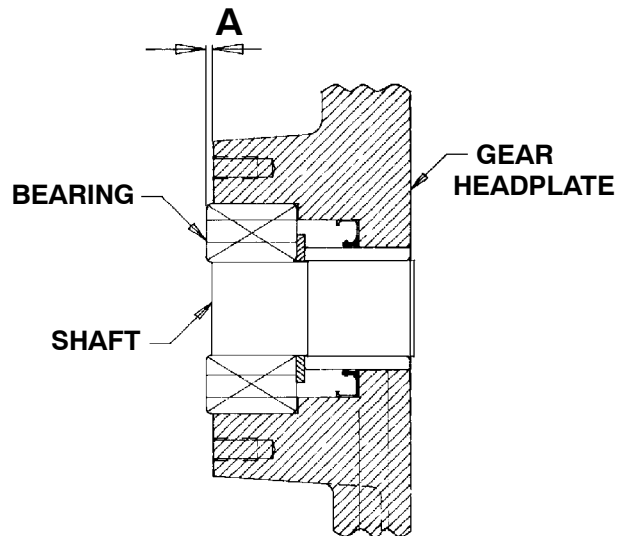

FIGURE 22

13. Impeller tip to case clearance should be checked at this time by inserting the correct thickness feeler gauge between the tip and the case (B) and rotating the impeller (see FIGURE 21, page 20). Repeat the procedure on both impellers.

## NOTICE

**When checking the tip to case clearance, move the feeler gauge over the entire length of the impeller to ensure that the tips do not bind along their length.**

14. Replace the drive shaft grease seal (31) in the drive end cover (29). The seal lip should always face toward the bearing or lubricant. Pack the bearing cavities with the recommended grease.
15. Secure drive cover (29) and wavy spring (28) to drive headplate using capscrews (30). Refer to FIGURE 24, page 24, for torque specifications.

## NOTICE

**Exercise care not to damage the seal lip as it passes over shaft keyway.**

## 16. SETTING IMPELLER END CLEARANCE

Refer to FIGURE 18, page 18. The gear end bearings are held in position by the force created by the wavy spring (28) on the drive end and the bearing retainer (12) on the gear end. The interference fit between the shaft (H) and the bearing inner race (E) keeps the shaft from moving axially.

End clearance adjustment of both impellers is controlled by adjustment of the bearing retainer (12). Tightening the bearing retainer screws (10) moves the bearing to load the wavy spring (28), and the impeller is forced toward the drive end. Relaxing the screws allows the wavy spring to return the impeller toward the gear end.

- A. With impellers tight against the gear headplate, measure the distance (A) from the bearing outer race to the gear headplate using a depth micrometer (see FIGURE 22, page 21).
- B. Subtract  $1/3$  of the total end clearance from the value measured at point A. This value is the amount of shim (13) that should be placed between the retainer and the headplate at point (S).
- C. Secure bearing retainer (12) with the correct amount of shim, to the headplate using capscrews (10). Torque capscrews to the specifications given in FIGURE 24, page 24.
- D. Recheck end clearances. Approximately  $1/3$  of the total end clearance should be on the gear end and the remaining  $2/3$  on the drive end (refer to FIGURE 21, page 20).

If clearances require adjusting, loosen the bearing retainer capscrews (10) and insert shims to move the impeller closer to the gear headplate and remove shims to move the impellers away from the gear headplate.

## 17. INSTALLING THE TIMING GEARS

Impellers are held in time by gears which are taper pinned and bolted to a timing hub, which in turn is pressed and taper pinned onto the shaft. The timing gears can be rotated in relation to the hub by removing the taper pins in the web of the gear and loosening the capscrews. Because the capscrews are oversized, the gear will rotate - within limits - relative to the timing hub when the screws are loosened.

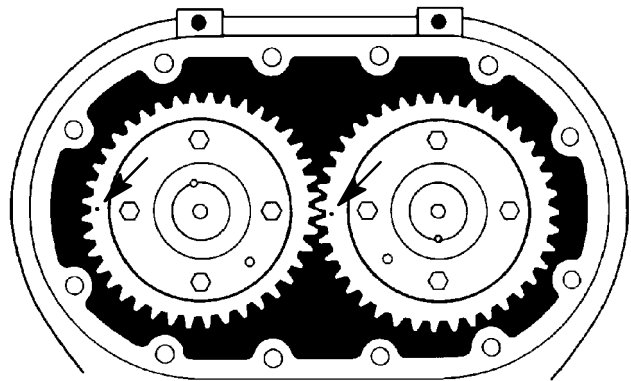

FIGURE 23

- A. Apply a light grease, or oil, on the shaft area where the timing gear will be positioned.
- B. Lubricate the inside diameter of spacers (32) with assembly lubricant and install on the gear end shafts.
- C. Using a piece of paper large enough to cover the open end of the gear headplate, trace the shafts on the paper and cut-out shaft holes. This will be placed on the shafts before the gears to protect the bearings from metal shavings when drilling taper pin holes in the following procedure.
- D. Place feeler stock in the amount of  $1/3$  of the total end clearance between drive headplate and both impellers. This will stop the impellers from contacting the headplate while the gears are being driven on.



### CAUTION

**If installing gears on a blower containing mechanical seals, a press must be used to drive the gears on the shafts. Blows from a hammer or mallet will damage the seal.**

- E. If reusing the timing gears and hubs, they should be returned to their original position with respect to the impellers.

If replacement gears are used, secure each gear (9) to its timing hub (39) with capscrews (38) and lockwasher (37) and tighten slightly.

## NOTICE

**Replacement gears have minimum backlash marks on the outside diameter of the gear face. These marks should be located 180 degrees from each other (see FIGURE 23).**

- F. Position impellers so they are 90 degrees to each other. Using the driving tool shown on page 12, install the gears and hubs on the shafts using the taper pin holes and match marks for correct positioning. Check to be sure impellers are in correct position as previously match marked.

## NOTICE

**Utilize a press whenever possible when installing gears.**

- G. Refer to diagram in FIGURE 21, page 20. Use feeler gauges to check clearances between impeller lobes at positions A-A and C-C. Add the clearances, and divide the total clearance evenly between A-A and C-C.
- H. Loosen the four capscrews (38) in one gear only. Wedge the correct amount of feeler gauge between the impeller at A-A. If movement between the gear and hub is not sufficient to time the impellers, it will be necessary to loosen the four capscrews (38) in the mating gear to obtain a large adjustment range. Adjust so that the clearance at A-A is equal to C-C within .001 inch.

Clearances must be checked on both sides of each impeller lobe over the entire length. This procedure may require repeating several times until impeller lobe clearance is equal on both sides.

- I. Secure the timing gears (9) to the hubs (39) with capscrews (38) and lockwasher (37). Tighten capscrews to the torque specification listed in FIGURE 24, page 24.
- J. Check gear backlash four places at 90 degree intervals as described in the disassembly procedure (Item 4).

## NOTICE

**If any of the four gear backlash readings are not within the specified limits, the gears must be replaced.**

- K. Reream taper pin hole between the shaft and hub with a hand reamer and replace taper pin (8) if movement between the shaft and hub (39) was negligible. If rereaming fails to eliminate edges due to slight misalignment, drill and ream a new hole approximately 90 degrees from the original hole. Control the depth of the taper pin, leaving approximately 1/8" taper pin protruding beyond the hub and shaft.
- L. Reream center drilled hole in the hub and gear web. If rereaming fails to eliminate edges set up by retiming, ream hole for the next larger taper pin or drill and ream a new hole approximately 90 degrees from the original hole. Control the depth of the threaded taper pin (36), leaving the threaded portion of the pin protruded beyond the hub.

Replacement gears are not drilled for taper pin (8). These holes must be drilled and reamed after the gears are in proper position and the unit retimed.

## NOTICE

**Be careful not to allow cuttings to drop behind the gears and contaminate the bearings.**

- M. Remove paper from behind the gears. Make certain metal cuttings did not contaminate the bearings.
- 18. Assemble gear cover (3) and gasket (7) to the gear headplate (18) using capscrews (5). Tighten capscrews alternately and evenly. Refer to FIGURE 24, page 24 for torque specifications.
- 19. Place blower on its feet on a flat surface. Loosen capscrews (16) and level unit up. The bench or blower base flatness should be within .002 of an inch. Re-tighten cap screws (16) to the specifications in FIGURE 24, page 24.

Ref. No.	FASTENERS	GEAR DIAMETER		
		6	7	8
5	Screw - Gear Case to Headplate	16	30	30
10	Screw - Bearing Retainer to Headplate	16	30	30
16	Screw - Mounting Foot to Headplate	30	75	75
21	Screw - Headplate to Impeller Case	30	75	75
30	Screw - Drive Cover to Headplate	16	30	30
38	Screw - Timing Hub to Gear	30	75	75

NOTE: REF. NO. DENOTES ITEMS IN EXPLODED VIEW DRAWINGS ON PAGES 25, 27 AND 29.

**FIGURE 24 - TORQUE (FT-LBS)**

# SECTION 8 PARTS LIST

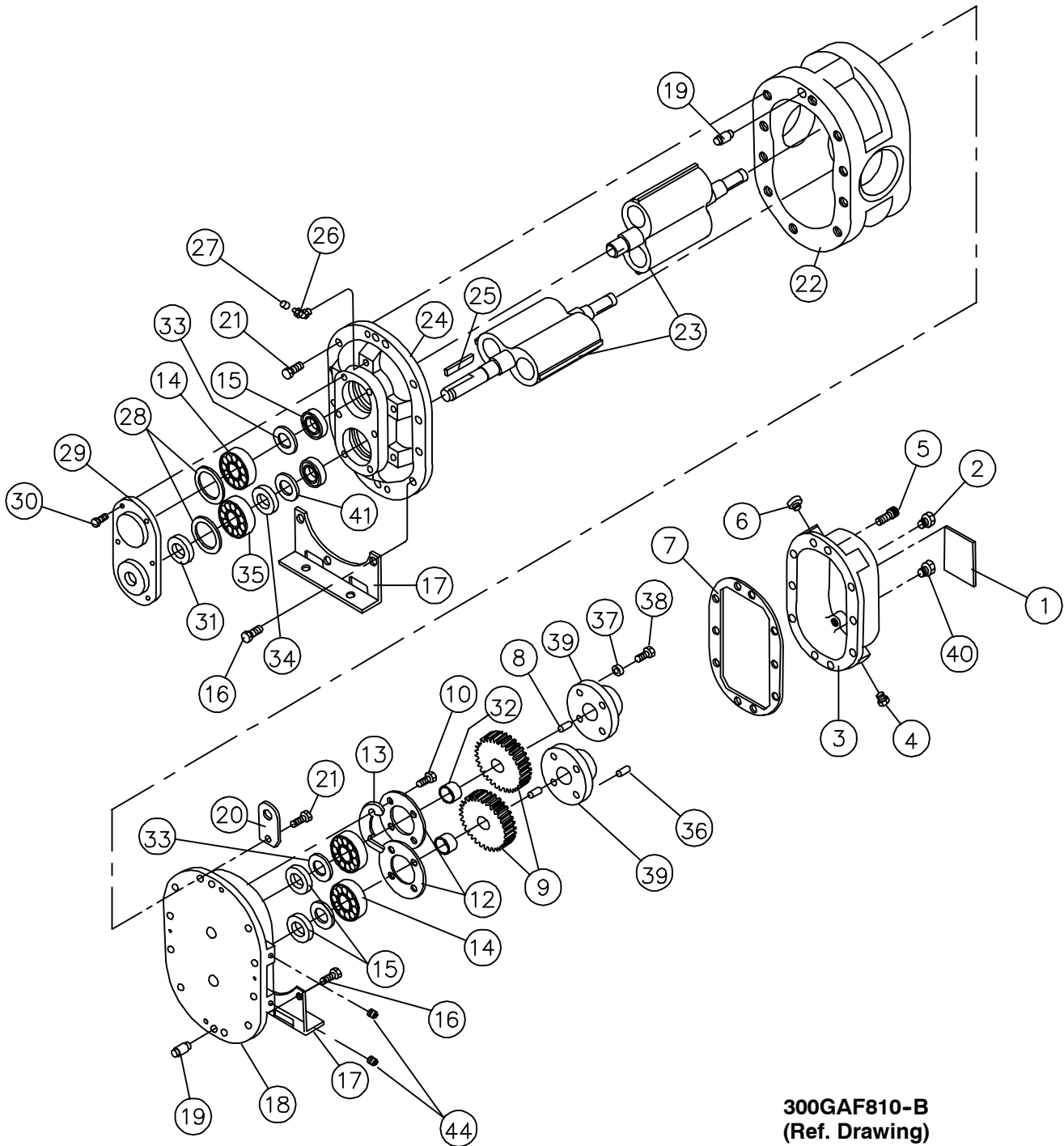

**300GAF810-B  
(Ref. Drawing)**



**Order by Part Number and Description. Reference Numbers are for your convenience only.**

Ref. No.	Description	No. Req'd	MODEL GAF		
			Size - 6H GAFH_P_	Size - 6M GAFM_P_	Size - 6L GAF6_P_
1	NAMEPLATE .....	1	301GAE496	301GAE496	301GAE496
2	PLUG FOR ALTERNATE OIL LEVEL CONN. ....	1	64AC4	64AC4	64AC4
3	GEAR CASE .....	1	900883064201	900883064201	900883064201
4	DRAIN PLUG .....	1	64AC4	64AC4	64AC4
5	SCREW-GEAR CASE TO HEADPLATE .....	12	75LM113	75LM113	75LM113
6	BREATHER .....	1	5L223	5L223	5L223
Ø 7	GASKET GEAR CASE .....	1	200GAF715	200GAF715	200GAF715
Ø 8	TAPER PIN .....	2	62V59	62V59	62V59
9	TIMING GEAR GROUP .....	1	200GAF6008	200GAF6008	200GAF6008
Ø 10	SCREW-BEARING RETAINER TO HEADPLATE .....	8	75A33N	75A33N	75A33N
12	BEARING RETAINER .....	2	900883065501	900883065501	900883065501
Ø 13	SHIM SET .....	1	900881065400	900881065400	900881065400
Ø 14	BEARING .....	3	900639080506	900639080506	900639080506
Ø 15	MAIN SEAL-PER APPLICATION BELOW				
	MECHANICAL SEAL VERSION .....	4	900871020006	900871020006	900871020006
	LIP SEAL VERSION .....	4	60DD657	60DD657	60DD657
16	SCREW-FOOT TO HEADPLATE .....	8	655ED060	655ED060	655ED060
17	FOOT GROUP				
	VERTICAL FOOT GROUP .....	1	GAF81950	GAF81950	GAF81950
	HORIZONTAL FOOT GROUP .....	1	GAF81951	GAF81951	GAF81951
18	HOUSING-BEARING (GEAR END) .....				
	LIP SEAL .....	1	900883064401	90088364401	900883064401
	MECHANICAL SEAL .....	1	900883064501	90088364501	900883064501
19	DOWEL PIN .....	4	62M48	62M48	62M48
20	LIFTING LUG .....	2	200GAF451	200GAF451	200GAF451
21	SCREW-HEADPLATES TO IMPELLER CASE .....	24	655ED050	655ED050	655ED050
22	IMPELLER CASE .....	1	900883063901	900883064001	900883064101
23	SHAFT ASSEMBLY GROUP .....	1	GAF81952	GAF81954	GAF81953
	SHAFT ASSEMBLY GROUP CONSISTS OF:				
	(1) ASSEMBLY SHAFT - LONG				
	(1) ASSEMBLY SHAFT - SHORT				
24	HOUSING-BEARING (DRIVE END)				
	LIP SEAL .....	1	900883064901	900883064901	900883064901
	MECHANICAL SEAL .....	1	900883064801	900883064801	900883064801
25	DRIVE KEY .....	1	900639910406	900639910406	900639910406
26	GREASE FITTING .....	2	911659990606	911659990606	911659990606
27	GREASE FITTING CAP .....	2	40P41	40P41	40P41
28	WAVY SPRING .....	2	900669170506	900669170506	900669170506
29	DRIVE COVER .....	1	900883064601	900883064601	900883064601
30	SCREW-DRIVE COVER TO HEADPLATE .....	8	75LM113	75LM113	75LM113
Ø 31	DRIVE SEAL .....	1	60DD658	60DD658	60DD658
32	SPACER-GEAR END .....	2	900811060401	900811060401	900811060401
33	SPACER-GEAR & DRIVE END-SEAL/BRG .....	3	900881066201	900881066201	900881066201
34	SPACER-DRIVE END DRIVE SHAFT-SEAL/BRG .....	1	900881066401	900881066401	900881066401
Ø 35	BEARING-DRIVE END DRIVE SHAFT .....	1	900811060801	900811060801	900811060801
36	THREADED TAPER PIN .....	2	62V67	62V67	62V67
37	WASHER-GEAR .....	8	900649440205	900649440205	900649440205
38	SCREW-TIMING HUB TO GEAR .....	8	655ED060	655ED060	655ED060
39	HUB-TIMING .....	2	900713060101	900713060101	900713060101
40	GAUGE-OIL LEVEL .....	1	40P31	40P31	40P31
* 41	SPACER-DRIVE END DRIVE SHAFT-HD PLT-BRG .....	1	900881066301	900881066301	900881066301
	REQUIRED WITH MECHANICAL SEAL UNITS				
* 42	PLUGS REQUIRED WITH MECHANICAL SEAL UNITS .....	8	64AC2	64AC2	64AC2
44	SCREW-SET .....	4	76F92	76F92	76F92
Ø	OVERHAUL KIT LIP SEAL .....	0	203GAF6010	203GAF6010	203GAF6010
Ø	OVERHAUL KIT MECHANICAL SEAL .....	0	204GAF6010	204GAF6010	204GAF6010

\* NOT SHOWN

Ø INCLUDED IN OVERHAUL KIT.

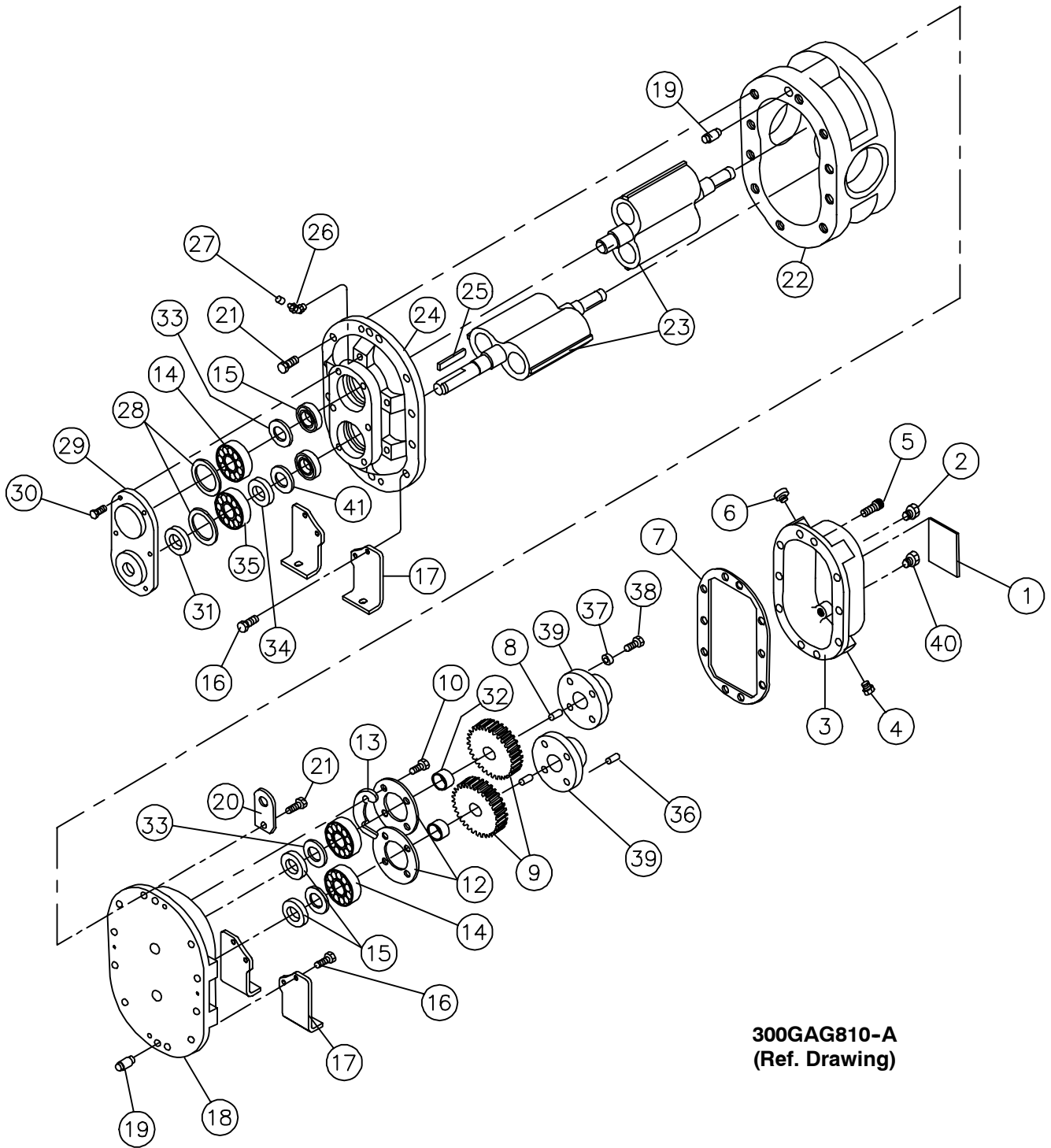

**300GAG810-A**  
**(Ref. Drawing)**

**Order by Part Number and Description. Reference Numbers are for your convenience only.**

Ref. No.	Description	No. Req'd	MODEL GAG		
			Size - 7H GAGH_P_	Size - 7M GAGM_P_	Size - 7L GAGL_P_
1	NAMEPLATE .....	1	301GAE496	301GAE496	301GAE496
2	PLUG FOR ALTERNATE OIL LEVEL CONN. ....	1	64B4	64B4	64B4
3	GEAR CASE .....	1	900893071701	900893071701	900893071701
4	DRAIN PLUG .....	1	64AC6	64AC6	64AC6
5	SCREW-GEAR CASE TO HEADPLATE .....	12	75LM122	75LM122	75LM122
6	BREATHER .....	1	5L223	5L223	5L223
Ø 7	GASKET GEAR CASE .....	1	200GAG715	200GAG715	200GAG715
Ø 8	TAPER PIN .....	2	62V60	62V60	62V60
9	TIMING GEAR GROUP .....	1	200GAG6008	200GAG6008	200GAG6008
Ø 10	SCREW-BEARING RETAINER TO HEADPLATE .....	8	655ED040N	655ED040N	655ED040N
12	BEARING RETAINER .....	2	900893070401	900893070401	900893070401
Ø 13	SHIM SET .....	1	900891073800	900891073800	900891073800
Ø 14	BEARING .....	3	DF138116	DF138116	DF138116
Ø 15	MAIN SEAL-PER APPLICATION BELOW				
	MECHANICAL SEAL VERSION .....	4	900871020007	900871020007	900871020007
	LIP SEAL VERSION .....	4	60DD715	60DD715	60DD715
16	SCREW-FOOT TO HEADPLATE .....	8	655EE070	655EE070	655EE070
17	FOOT GROUP				
	VERTICAL FOOT GROUP .....	1	GAG81958	GAG81958	GAG81958
	HORIZONTAL FOOT GROUP .....	1	GAG81959	GAG81959	GAG81959
18	HOUSING-BEARING (GEAR END) .....				
	LIP SEAL .....	1	900893072801	900893072801	900893072801
	MECHANICAL SEAL .....	1	200GAG006	200GAG006	200GAG006
19	DOWEL PIN .....	4	62M48	62M48	62M48
20	LIFTING LUG .....	2	200GAF451	200GAF451	200GAF451
21	SCREW-HEADPLATES TO IMPELLER CASE .....	24	655EE050	655EE050	655EE050
22	IMPELLER CASE .....	1	900893070101	900893070201	900893070301
23	SHAFT ASSEMBLY GROUP .....	1	GAG81960	GAG81962	GAG81961
	SHAFT ASSEMBLY GROUP CONSISTS OF:				
	(1) ASSEMBLY SHAFT - LONG				
	(1) ASSEMBLY SHAFT - SHORT				
24	HOUSING-BEARING (DRIVE END)				
	LIP SEAL .....	1	900893070601	900893070601	900893070601
	MECHANICAL SEAL .....	1	900893072601	900893072601	900893072601
25	DRIVE KEY .....	1	900639910407	900639910407	900639910407
26	GREASE FITTING .....	2	911659990606	911659990606	911659990606
27	GREASE FITTING CAP .....	2	40P41	40P41	40P41
28	WAVY SPRING .....	2	900669170607	900669170607	900669170607
29	DRIVE COVER .....	1	900883073701	900883073701	900883073701
30	SCREW-DRIVE COVER TO HEADPLATE .....	8	75LM122	75LM122	75LM122
Ø 31	DRIVE SEAL .....	1	60DD727	60DD727	60DD727
32	SPACER-GEAR END .....	2	900891073001	900891073001	900891073001
33	SPACER-GEAR & DRIVE END-SEAL/BRG .....	3	200GAG144	200GAG144	200GAG144
34	SPACER-DRIVE END DRIVE SHAFT-SEAL/BRG .....	1	201GAG144	201GAG144	201GAG144
Ø 35	BEARING-DRIVE END DRIVE SHAFT .....	1	910712068201	910712068201	910712068201
36	THREADED TAPER PIN .....	2	62V68	62V68	62V68
37	WASHER-GEAR .....	8	900649440507	900649440507	900649440507
38	SCREW-TIMING HUB TO GEAR .....	8	655EE060	655EE060	655EE060
39	HUB-TIMING .....	2	900713060102	900713060102	900713060102
40	GAUGE-OIL LEVEL .....	1	VP1004935	VP1004935	VP1004935
* 41	SPACER-DRIVE END DRIVE SHAFT-HD PLT-BRG .....	1	900881073301	900881073301	900881073301
	REQUIRED WITH MECHANICAL SEAL UNITS				
* 42	PLUGS REQ. W/MECH. SEAL UNITS(GEAR END) .....	4	64AC3	64AC3	64AC3
* 46	PLUGS REQ. W/MECH. SEAL UNITS (DRIVE END) .....	4	64AC2	64AC2	64AC2
Ø	OVERHAUL KIT LIP SEAL .....	0	200GAG6010	200GAG6010	200GAG6010
Ø	OVERHAUL KIT MECHANICAL SEAL .....	0	201GAG6010	201GAG6010	201GAG6010

\* NOT SHOWN

Ø INCLUDED IN OVERHAUL KIT.

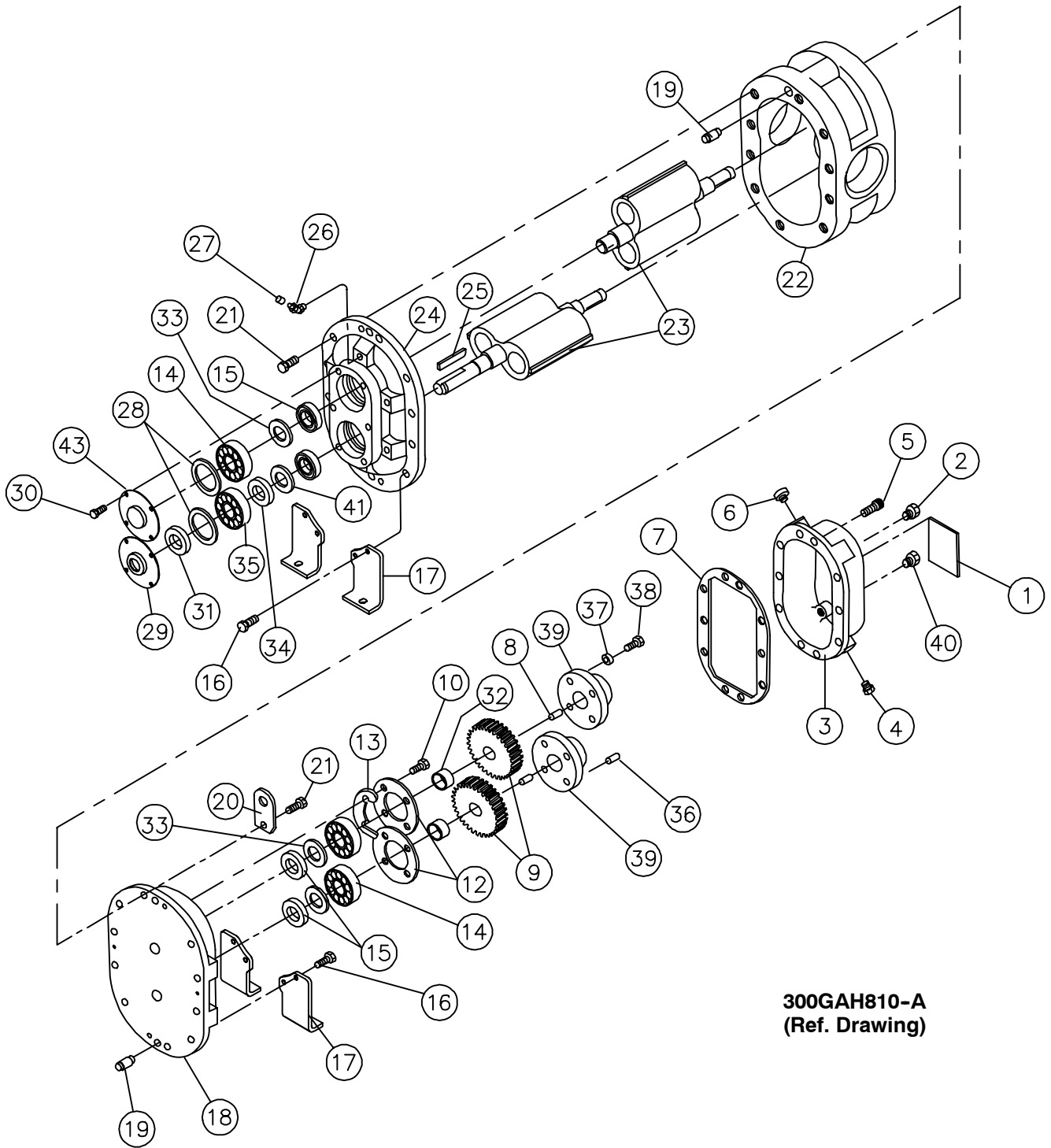

**300GAH810-A  
(Ref. Drawing)**

**Order by Part Number and Description. Reference Numbers are for your convenience only.**

Ref. No.	Description	No. Req'd	MODEL GAH		
			Size - 8H GAHH_P_	Size - 8M GAHM_P_	Size - 8L GAHL_P_
1	NAMEPLATE .....	1	301GAE496	301GAE496	301GAE496
2	PLUG FOR ALTERNATE OIL LEVEL CONN. ....	1	64AC5	64AC5	64AC5
3	GEAR CASE .....	1	900893082501	900893082501	900893082501
4	DRAIN PLUG .....	1	64AC5	64AC5	64AC5
5	SCREW-GEAR CASE TO HEADPLATE .....	12	2009649	2009649	2009649
6	BREATHER .....	1	5L223	5L223	5L223
Ø 7	GASKET GEAR CASE .....	1	200GAH715	200GAH715	200GAH715
Ø 8	TAPER PIN .....	2	62V61	62V61	62V61
9	TIMING GEAR GROUP .....	1	200GAH6008	200GAH6008	200GAH6008
10	SCREW-BEARING RETAINER TO HEADPLATE .....	8	655ED04N	655ED04N	655ED04N
11	LOCKWASHER .....	8	95B3	95B3	95B3
12	BEARING RETAINER .....	2	900893083101	900893083101	900893083101
Ø 13	SHIM SET .....	1	910639630008	910639630008	910639630008
Ø 14	BEARING .....	3	900639080808	900639080808	900639080808
Ø 15	MAIN SEAL-PER APPLICATION BELOW MECHANICAL SEAL VERSION .....	4	900871020008	900871020008	900871020008
	LIP SEAL VERSION .....	4	910751061902	910751061902	910751061902
16	SCREW-FOOT TO HEADPLATE .....	8	655EE080	655EE080	655EE080
17	FOOT GROUP				
	VERTICAL FOOT GROUP .....	1	GAH81966	GAH81966	GAH81966
	HORIZONTAL FOOT GROUP .....	1	GAH81967	GAH81967	GAH81967
18	HOUSING-BEARING (GEAR END) .....				
	LIP SEAL .....	1	900894082301	900894082301	900894082301
	MECHANICAL .....	1	200GAH006	200GAH006	200GAH006
19	DOWEL PIN .....	4	62M48	62M48	62M48
20	LIFTING LUG .....	2	200GAF451	200GAF451	200GAF451
21	SCREW-HEADPLATES TO IMPELLER CASE .....	36	655EE060	655EE060	655EE060
22	IMPELLER CASE .....	1	900653021708	910613746808	910613747008
23	SHAFT ASSEMBLY GROUP .....	1	GAH81968	GAH81970	GAH81969
	SHAFT ASSEMBLY GROUP CONSISTS OF: (1) ASSEMBLY SHAFT - LONG (1) ASSEMBLY SHAFT - SHORT				
24	HOUSING-BEARING (DRIVE END)				
	LIP SEAL .....	1	900894082101	900894082101	900894082101
	MECHANICAL SEAL .....	1	201GAH006	201GAH006	201GAH006
25	DRIVE KEY .....	1	900639910407	900639910407	900639910407
26	GREASE FITTING .....	2	911659990606	911659990606	911659990606
27	GREASE FITTING CAP .....	2	40P41	40P41	40P41
28	WAVY SPRING .....	2	900669170708	900669170708	900669170708
29	DRIVE COVER .....	1	900693086301	900693086301	900693086301
30	SCREW-DRIVE COVER TO HEADPLATE .....	8	655ED030	655ED030	655ED030
Ø 31	DRIVE SEAL .....	1	60DD676	60DD676	60DD676
32	SPACER-GEAR END .....	2	900811060403	900811060403	900811060403
33	SPACER-GEAR & DRIVE END - SEAL/BRG .....	3	900871060803	900871060803	900871060803
34	SPACER-DRIVE END DRIVE SHAFT-SEAL/BRG .....	1	202GAH144	202GAH144	202GAH144
Ø 35	BEARING-DRIVE END DRIVE SHAFT .....	1	910721070501	910721070501	910721070501
36	THREADED TAPER PIN .....	2	62V69	62V69	62V69
37	WASHER-GEAR .....	8	900649440507	900649440507	900649440507
38	SCREW-TIMING HUB TO GEAR .....	8	655EE080	655EE080	655EE080
39	HUB-TIMING .....	2	900713060103	900713060103	900713060103
40	GAUGE-OIL LEVEL .....	1	40P45	40P45	40P45
* 41	SPACER-DRIVE END DRIVE SHAFT-HD PLT-BRG .....	1	900881082401	900881082401	900881082401
	REQUIRED WITH MECHANICAL SEAL UNITS				
* 42	PLUGS REQUIRED WITH MECHANICAL SEAL UNITS .....	8	64AC3	64AC3	64AC3
43	DRIVEN COVER .....	1	900693086401	900693086401	900693086401
Ø	OVERHAUL KIT LIP SEAL .....	0	GAH81972	GAH81972	GAH81972
Ø	OVERHAUL KIT MECHANICAL SEAL .....	0	GAH81971	GAH81971	GAH81971

\* NOT SHOWN

Ø INCLUDED IN OVERHAUL KIT.

**SUTORBILT BLOWERS  
SUTORBILT LEGEND SERIES****GENERAL PROVISIONS AND LIMITATIONS**

Gardner Denver (the "Company") warrants to each original retail purchaser ("Purchaser") of its new products from the Company or its authorized distributor that such products are, at the time of delivery to the Purchaser, made with good material and workmanship. No warranty is made with respect to:

1. Any product which has been repaired or altered in such a way, in the Company's judgment, as to affect the product adversely.
2. Any product which has, in the Company's judgment been subject to negligence, accident, improper storage, or improper installation or application.
3. Any product which has not been operated or maintained in accordance with normal practice and with the recommendations of the Company.
4. Components or accessories manufactured, warranted and serviced by others.
5. Any reconditioned or prior owned product.

Claims for items described in (4) above should be submitted directly to the manufacturer.

**WARRANTY PERIOD**

The Company's obligation under this warranty is limited to repairing or, at its option, replacing, during normal business hours at an authorized service facility of the Company, any part which in its judgment proved not to be as warranted within the applicable Warranty Period as follows.

**BARE BLOWERS**

Basic bare blowers, consisting of all parts within, are warranted for 18 months from date of initial use or 24 months from date of shipment to the first purchaser, whichever occurs first.

Any disassembly or partial disassembly of the blower, or failure to return the "unopened" blower per Company instructions, will be cause for denial of warranty.

**OTHER COMPONENTS**

All other components are warranted for 12 months from date of initial use or 18 months from date of shipment to first purchaser, whichever comes first.

The Company reserves the right to withdraw the Uncontested Warranty where evidence indicates application outside the stated performance area, or where there is evidence of abuse

**LABOR TRANSPORTATION AND INSPECTION**

The Company will provide labor, by Company representative or authorized service personnel, for repair or replacement of any product or part thereof which in the

Company's judgment is proved not to be as warranted. Labor shall be limited to the amount specified in the Company's labor rate schedule.

Labor costs in excess of the Company rate schedule amounts or labor provided by unauthorized service personnel is not provided for by this warranty.

Transportation of Company's choice, within the continental United States, is covered by this warranty for replacement of any blower which in the Company's judgement proved not to be as warranted. For user locations outside the continental United States, the Company will provide transportation, by the carrier of its choice to and from the nearest Authorized Distributor and the Company's designated facility. The Company may require the return of any blower claimed not to be as warranted to one of its facilities as designated by the Company, transportation prepaid by Purchaser, to establish a claim under this warranty.

Replacement parts provided under the terms of the warranty are warranted for the remainder of the Warranty Period of the product upon which installed to the same extent as if such parts were original components thereof.

**DISCLAIMER**

THE FOREGOING WARRANTY IS EXCLUSIVE AND IT IS EXPRESSLY AGREED THAT, EXCEPT AS TO TITLE, THE COMPANY MAKES NO OTHER WARRANTIES, EXPRESSED, IMPLIED OR STATUTORY, INCLUDING ANY IMPLIED WARRANTY OF MERCHANTABILITY.

THE REMEDY PROVIDED UNDER THIS WARRANTY SHALL BE THE SOLE, EXCLUSIVE AND ONLY REMEDY AVAILABLE TO PURCHASER AND IN NO CASE SHALL THE COMPANY BE SUBJECT TO ANY OTHER OBLIGATIONS OR LIABILITIES. UNDER NO CIRCUMSTANCES SHALL THE COMPANY BE LIABLE FOR SPECIAL, INDIRECT, INCIDENTAL OR CONSEQUENTIAL DAMAGES, EXPENSES, LOSSES OR DELAYS HOWSOEVER CAUSED.

No statement, representation, agreement, or understanding, oral or written, made by any agent, distributor, representative, or employee of the Company which is not contained in this Warranty will be binding upon the Company unless made in writing and executed by an officer of the Company.

This warranty shall not be effective as to any claim which is not presented within 30 days after the date upon which the product is claimed not to have been as warranted. Any action for breach of this warranty must be commenced within one year after the date upon which the cause of action occurred.

Any adjustment made pursuant to this warranty shall not be construed as an admission by the Company that any product was not as warranted.

---

**Gardner**  
**Denver**

Specifications subject to change without notice  
© Copyright 2005 Gardner Denver, Inc. Litho in U.S.A.

For additional information, contact your local representative or

**Gardner Denver Compressor Division**

1800 Gardner Expressway, Quincy, Illinois 62305

Phone (800) 682-9868 • Fax (217) 221-8780

E-mail: [pd.blowers@gardnerdenver.com](mailto:pd.blowers@gardnerdenver.com)

Visit our web site: [www.gardnerdenver.com](http://www.gardnerdenver.com)

Sales and Service in all major cities

